

# OUT WITH THE OLD AND IN WITH THE NEW



## THE SOLARIUM 6700 ALPHA

The 6700 alpha provides the maximum of technology, comfort and first class at an unbeatable price-performance ratio. This is luxury at a price made for starters!



UV LAMPS



GLASS FACIAL SYSTEM



X-TRA TAN



EASY CONTROL



COLOR MOTION



AIR CONDITION



AQUA COOL

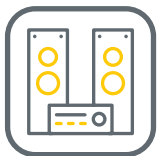

SOUND SYSTEM

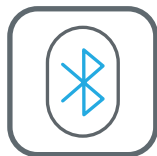

BLUETOOTH



MEGA VOICE



CPI

# TECHNICAL DATA – 6700 ALPHA

Power consumption:	14 kW
Weight:	~1367 lbs (with air conditioning)
Bench pane:	330 lbs (max. load capacity)

## ELECTRICAL REQUIREMENTS

Power connection:	rear side left
Protective class:	IP20
Mains voltage:	3-phase: 3 x 220 V / ~ / 60 Hz
Wire cross section:	3-phase: 4 x AWG6
Circuit breaker recommended:	3-phase: 3 x 50 A

All tanning devices with Class-A ground fault circuit interrupter GFCI.

## CENTRAL EXHAUST AIR DISCHARGE

Fan:	Exhaust-air socket Ø ~11.81 inch Height to top ~82.48 inch
Minimum exhaust air flow rate:	594400 gal/hour
Exhaust-air hose:	Ø ~11.81 inch

## DIMENSIONS

Recommended roomsize:	9' x 10'
Dimensions in inch (HxWxD):	~60.39" x ~93.70" x ~56.30" (closed) ~76.46" x ~93.70" x ~56.30" (open)

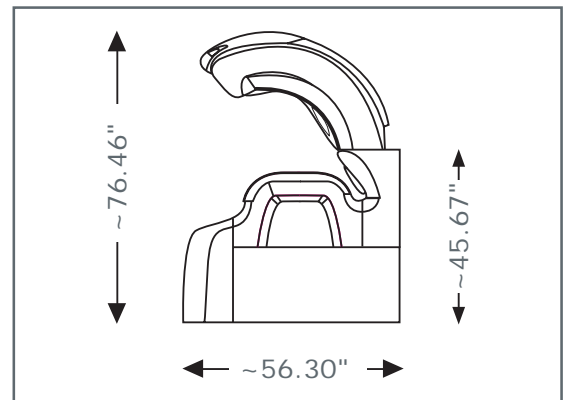
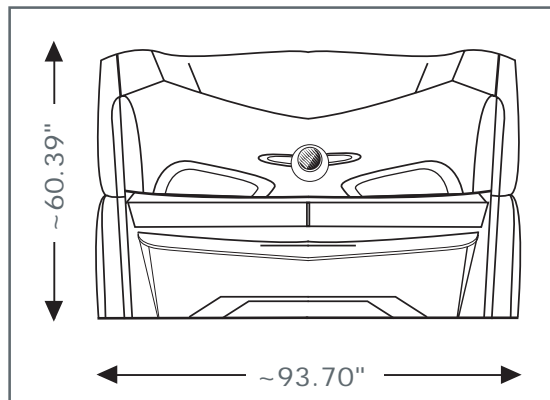

Contraindication: This product is contraindicated for use on persons under the age of 18 years. "Contraindication: This product must not be used if skin lesions or open wounds are present." "Warning: This product should not be used on individuals who have had skin cancer or have a family history of skin cancer." "Warning: Persons repeatedly exposed to UV radiation should be regularly evaluated for skin cancer."