

# SPORTARREDO® GROUP

SPORTARREDO GROUP S.C.  
VIA DELL' INDUSTRIA 7  
GRUARO 30020 (VE) ITALY  
Tel. 0421/767676 Fax 0421/767670

# HPO

MODEL HPO TANNING BOOTH  
SUNLAMP PRODUCT INTENDED FOR USE TO TAN THE SKIN

**100%**   
**MADE IN ITALY**

**INSTALLATION, USE AND MAINTENANCE MANUAL**

**USA**

Cod.app.:10097.028.2.0 (230V 3~ 60Hz)  
Cod.app.:10099.003.1.0 (230V 1~ 60Hz)

**INDEX**

12.1 Limited warranty.....27

**INDEX OF SECTIONS****1 - GENERAL INFORMATION**

1.1 Labels.....	page. 2
1.2 Introduction.....	6
1.3 Intended Use.....	6
1.4 Exposure Schedule.....	6
1.5 Contraindications and Warnings Safety of the persons exposed to UV.....	7
1.6 Transport and handling.....	9
1.7 Preparation for installation by the client.....	9

**2 - SAFETY INFORMATION**

2.1 General.....	10
2.2 Noise.....	10
2.3 Regulations.....	10

**3 - TECHNICAL DATA**

3.1 Dimensions and technical data HPO EXOTIC.....	11
--	----

**4 - INSTALLATION**

4.1 Pre-installation.....	11
4.2 Connections.....	11
4.3 Assembly instructions.....	12
4.4 Voltage change.....	16

**5 - USE**

5.1 Control board.....	17
------------------------	----

**6 - MAINTENANCE PERFORMED BY THE CUSTOMER**

6.1 Customer maintenance & Cleaning Instructions.....	18
6.2 Recommended replacement and obtaining repairs.....	19

**7 - MAINTENANCE PERFORMED BY A SKILLED TECHNICIAN**

7.1 Skilled maintenance.....	20
7.2 Periodic control procedure.....	20
7.3 Thermal protection.....	21

**8 - THE BED USE A T-MAX® 005**

8.1 Table of contents.....	22
----------------------------	----

**9 - TROUBLESHOOTING AND RAPID DIAGNOSTICS**

9.1 Troubleshooting and rapid diagnostics.....	27
--	----

**10 - DEMOLITION AND WASTE MATERIALS**

10.1 Waste materials.....	27
10.2 Demolition of the machine.....	27

**11 - CIRCUIT DIAGRAMS**

11.1 Circuit diagrams legend.....	28
-----------------------------------	----

**12 - WARRANTY**

**1 - GENERAL INFORMATION****1.1 LABELS**

This device is intended to be used by only one person at a time. Stand in the middle of booth, with body positioned an equal distance from the surrounding lamps.

**CAUTION: EXPOSURE POSITIONS OTHER THAN SPECIFIED MAY RESULT IN OVEREXPOSURE AND ARE NOT RECOMMENDED.**

Tanning normally begins after one to two exposures and maximizes after one to four (1-4) weeks of exposure following the recommended schedule for your skin type.

**Wear protective eyewear.**

**Eyewear: SUN GLOBES**

Read the instruction booklet before using tanning system.

**RECOMMENDED EXPOSURE SCHEDULE**

First three sessions should be at 48 hour intervals. Followed by the gradual increasing of exposure times until maximum tanning has occurred (in approximately 4 weeks). MAXIMUM EXPOSURE is 10 minutes.

Skin Type	Week 1 1st - 3rd Session	Week 2 4th - 6th Session	Week 3 7th-9th Session	Subsequent Weekly Session
II	3 min	6 min	9 min	12 min
III	3 min	7 min	10 min	13 min
IV	3 min	7 min	10 min	13 min
V	3 min	8 min	11 min	15 min

This product is in conformity with performance standards for sunlamp products under 21 CFR 1040.20.

This appliance is intended to be used with the following lamps:

**Kalfasun 630F 600W**  
**Kalfasun 1530F 1500W**

For replacement lamps, eyewear or parts, contact:

**PC TAN**  
1040 Wilt Avenue  
07657, Ridgefield NJ - USA  
(201) 943-6100

Cod.16986.318.1.0

Cet appareil peut être utilisé par une personne à la fois. Se tenir en milieu de la douche, avec le corp à la même distance des lampes.

**AVERTISSEMENT: DES POSITIONS DE BRONZAGE DIFFÉRENTES DE CELLE QUI SONT RECOMMANDÉ PEUT CAUSER UNE SUREXPOSITION ET NE SONT PAS RECOMMANDÉ.**

Le bronzage normalement commence après une or deux expositions et augment après une de quatre (1-4) semaines, suivant le tableau recommandé pour votre peau. **User des lunettes protectrices.**

**Lunettes protectrices: SUN GLOBES**

Lire le livret des instructions avant d'utiliser l'appareil de bronzage.

**TABLEAU D'EXPOSITION RECCOMANDE'**

Les première quatre sessions doit respecter des intervalles de 48 heures. Suivant le progressif accroissement du temp d'exposition jusqu'au moment on a obtenu le maximum de bronzage (4 sessions). LE TEMP D'EXPOSITION MAXIMUM C'EST DE 10 MINUTES.

Type de peau	Semaine 1 1st - 3rd Session	Semaine 2 4th - 6th Session	Semaine 3 7th-9th Session	Suivant chaque semaine
II	3 min	6 min	9 min	12 min
III	3 min	7 min	10 min	13 min
IV	3 min	7 min	10 min	13 min
V	3 min	8 min	11 min	15 min

Cet appareil est en conformité avec la prestation ordinaire pour la lampe solaire produite au-dessous de No.21CFR1040.20.

Cet appareil peut être utilisé avec ces lampes :

**Kalfasun 630F 600W**  
**Kalfasun 1530F 1500W**

Pour remplacement de lampes,lunettes or de parties contacter :

**PC TAN**  
1040 Wilt Avenue  
07657, Ridgefield NJ - USA  
(201) 943-6100

Cod.16986.318.1.0

## 1 - GENERAL INFORMATION

## 1.1 LABELS



**WARNING—ULTRAVIOLET RADIATION—FOLLOW INSTRUCTIONS—FAILURE TO USE PROTECTIVE EYEWEAR MAY RESULT IN SEVERE BURNS OR OTHER EYE INJURY—IF DISCOMFORT DEVELOPS, DISCONTINUE USE AND CONSULT A PHYSICIAN**

**ATTENTION—RAYONNEMENTS ULTRAVIOLETS—VEUILLEZ SUIVRE LES INSTRUCTIONS—SANS DISPOSITIF DE PROTECTION DES YEUX, CE PRODUIT PEUT CAUSER DES BRÛLURES OU LÉSIONS OCULAIRES GRAVES—SI VOUS SENTEZ UN MALAISE, EN DISCONTINUER L'USAGE ET CONSULTER UN MÉDECIN**

Avoid overexposure. As with natural sunlight, overexposure can cause eye and skin injury and allergic reaction. Repeated exposure may cause premature ageing of the skin and cancer.  
Medications or cosmetics may increase your sensitivity to the ultraviolet radiation. Consult physician before using sunbed if you are using medications or have a history of skin problems or believe yourself especially sensitive to sun light. If you do not tan in the sun, you are unlikely to tan from use of this product.

Éviter surexposition. Comme avec la lumière naturelle du soleil, la surexposition peut causer lésions aux yeux et à la peau et réactions allergiques. Une exposition répétée peut causer un vieillissement prématuré de la peau et cancer.  
Médicaments et cosmétiques peuvent augmenter votre sensibilité aux rayons ultraviolets. Consulter un médecin avant d'utiliser la lampe à ultraviolets si vous utilisez médicaments, si vous avez problèmes de peau ou si vous croyez vous êtes particulièrement sensibles aux rayons du soleil. Si vous ne bronzez pas avec le soleil, c'est improbable que vous pouvez vous bronzier en utilisant ce produit.

Cod.16986.199.0.0

- AVVERTENZA: Non usare l' apparecchiatura se i filtri protettivi sono danneggiati o mancanti!
- ATTENTION: Do not use the sunbed if the filter glasses are missing or damaged!
- ACHTUNG: Bei defekter oder fehlender Filterscheibe keine Bestrahlung vomehment!
- ATTENTION: Quand le filtres de protection manque ou sont abimés, n' utilisez pas l' appareil!
- ATENCION: No utilizar el aparato si faltan los filtros protectores o si los mismos estan danados!

Cod.16986.203.0.0

CAUTION!  
CONNECT ONLY TO A CIRCUIT PROTECT BY A CLASS A  
GROUND FAULT CIRCUIT INTERRUPTER

ATTENTION!  
BRANCHER SEULEMENT A UNE DERIVATION PROTÉGÉE  
PAR UN DISJONCTEUR DIFFÉRENTIEL DE CLASSE A

(Valid only for CAN/CSA – Valable seulement pour CAN/CSA)

VALID ONLY FOR CAN/CSA

16986.200.1.0

**WARNING!**  
DISCONNECT POWER SUPPLY BEFORE OPENING UNIT

ACHTUNG!  
VOR DER ÖFFNUNG DES GERÄTES SICH VERGEWISSEN, DASS  
DIE ELEKTRIZITÄT ABGESCHALTET IST

ATTENTION!  
AVANT D' OUVRIRE D' APPAREIL, S' ASSURER QU' IL AIT ÊTE COUP  
LA TENSION D' ALIMENTATION

CUIDADO!  
ANTES DE ABRIR EL APARATO HAY QUE ASEGURARSE DE QUE  
ESTE CORTADA LA TENSION DE ALIMENTACION

ATTENZIONE!  
PRIMA DI APRIRE L' APPARECCHIO ACCERTARSI CHE SIA STATA  
TOLTA LA TENSIONE DI ALIMENTAZIONE

Cod.16986.001.0.0

**WARNING:**  
GROUNDING CIRCUIT CONTINUITY IS VITAL FOR SAFE OPERATION OF  
EQUIPMENT. NEVER OPERATE EQUIPMENT WITH GROUNDING CONDUCTOR  
DISCONNECTED.

**AVERTISSEMENT:**  
POUR UN FONCTIONNEMENT SÛR, NE JAMAIS UTILISER CET APPAREIL  
QUAND LE CONDUCTEUR DE MISE A LA MASSE EST DÉCONNECTÉ.

Cod.16986.137.0.0

**WARNING:**  
HIGH LEAKAGE CURRENT - ENSURE PROPER GROUNDING.

**AVERTISSEMENT:**  
COURANT DE FUITE ÉLEVÉ - FOURNIR UNE MISE A LA  
TERRE EFFICACE

Cod.16986.138.0.0

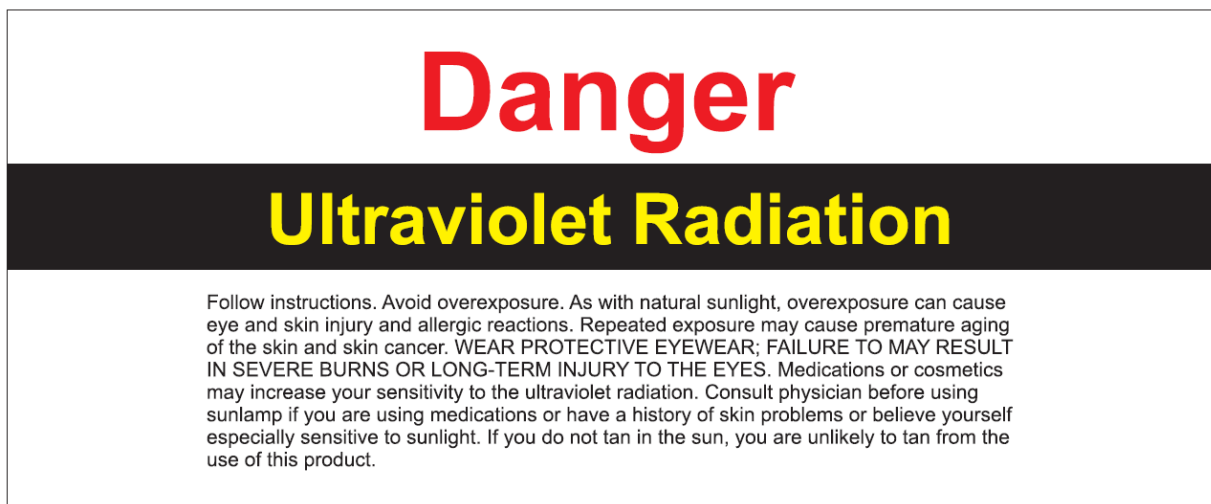

**1 - GENERAL INFORMATION****1.1 LABELS**

This electronic device conforms to UL STD 482 and is certified to CAN/CSA STD C22.2 NO.224

## 1 - GENERAL INFORMATION

### 1.2 INTRODUCTION

#### IMPORTANT

BEFORE OPERATING THE MACHINE, READ THE INSTRUCTIONS WITHIN THIS OPERATING MANUAL CAREFULLY AND COMPLETELY.

KEEP THIS MANUAL AND ALL ENCLOSURES IN AN ACCESSIBLE PLACE WHERE IT CAN BE REFERRED TO BY ALL USERS (OPERATORS, MAINTENANCE PERSONNEL AND THOSE CLIENTS WHO ASK FOR DETAILED INFORMATION).

This Operating Manual is designed for use by installers and operators, and should be read carefully and completely before the machine is operated. The manual should always be available for reference and should be kept in a safe place so that it stays in good condition for future reference. For further copies or updates of the manual, contact the manufacturer at the address on the front page.

This manual contains all the instructions and information necessary to operate the machine:

- Correct installation of the machine.
- Description of the functions of the machine.
- Circuit diagrams.

The installers and the operators can use this manual to understand the characteristics of the machine and to learn the correct operating procedure.

### 1.3 INTENDED USE

**Sunlamp product intended for use to tan the skin.**

### 1.4 EXPOSURE SCHEDULE

#### **DANGER!** Ultraviolet Radiation.

Follow instructions. Avoid overexposure. As with natural sunlight, overexposure can cause eye and skin injury and allergic reactions. Repeated exposure may cause premature aging of the skin and skin cancer.

**WEAR PROTECTIVE EYEWEAR; FAILURE TO MAY RESULT IN SEVERE BURNS OR LONG-TERM INJURY TO THE EYES.**

Medications or Cosmetics may increase your sensitivity to the ultraviolet radiation. Consult physician before using sunlamp if you are using medications or have a history of skin problems or believe yourself especially sensitive to sunlight. If you do not tan in the sun, you are unlikely to tan from the use of this product.

This device includes two pairs of protective eye-wear. Please note that this device is intended to be used by only one person at a time. Stand in the middle of booth, with body positioned an equal distance from the surrounding lamps.

**CAUTION:** EXPOSURE POSITIONS OTHER THAN SPECIFIED MAY RESULT IN OVEREXPOSURE AND ARE NOT RECOMMENDED.

Tanning normally begins after one to two exposures and maximizes after one to four (1-4) weeks of exposure following the recommended schedule for your skin type.

#### **Skin type II.**

This individual usually burns easily and severely; tans minimally or lightly and peels.

#### **Skin type III.**

This individual is often referred to as "average" skin type; burns moderately and tans about average.

#### **Skin type IV.**

This individual burns minimally; tans easily and above average.

#### **Skin type V.**

This individual rarely burns; tans easily and substantially.

Session times are calculated for a supply voltage of 208V.

This product is in conformity with performance standards for sunlamp products under 21 CFR 1040.20.

#### RECOMMENDED EXPOSURE SCHEDULE

First three sessions should be at 48 hour intervals. Followed by the gradual increasing of exposure times until maximum tanning has occurred (in approximately 4 weeks). MAXIMUM EXPOSURE is 15 minutes.

Skin type	Week 1 1st-3rd Session	Week 2 4rd-6rd Session	Week 3 7rd-9rd Session	Subsequent Weekly Session
II	3 min.	7 min.	10 min.	12 min.
III	3 min.	7 min.	10 min.	13 min.
IV	3 min.	8 min.	11 min.	14 min.
V	3 min.	8 min.	12 min.	15 min.

This schedule is intended to be used with the following lamps and filters:

Lamp Kalfasun 1530F

Lamp Kalfasun 630F

Blue cobalt filter and clear Superlux TR-T - Ultralux filter (together).

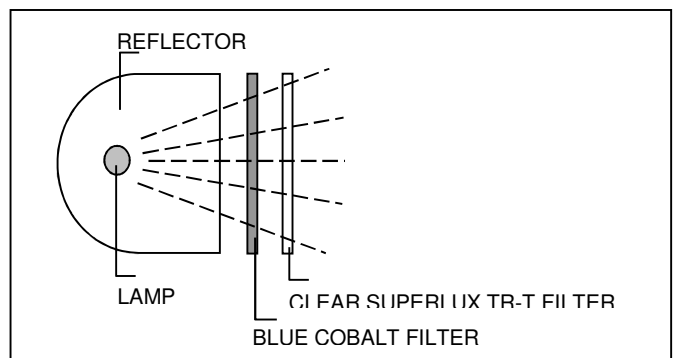

**1.5 CONTRAINDICATIONS AND WARNINGS FOR THE SAFETY OF THE PERSONS EXPOSED TO UV**

- **Contraindication:** This product is contraindicated for use on persons under the age of 18 years.
- **Contraindication:** This product must not be used if skin lesions or open wounds are present.
- **Warning:** This product should not be used on individuals who have had skin cancer or have a family history of skin cancer.
- **Warning:** Persons repeatedly exposed to UV radiation should be regularly evaluated for skin cancer.

**Do not use** the unit in case of filter damages and timer faults!

**ATTENTION!**  
**AN IMPROPER OR INCORRECT USE OF THE UNIT CAN CAUSE SERIOUS BODILY DAMAGE TO THE PERSON EXPOSED!**

From a careful analysis, as specified in **EN 60335-2-27**, the precautions that must be observed are listed below.

**Precautions:**

- Leave at least a 48 hours interval before to expose again yourself to the next tanning session.
- Do not expose yourself to the unit and sun in the same day.
- Do not expose yourself to the appliance if you usually burn with normal sunlight or if you suffer from sun-rash.
- Do not attend UV session in case of pregnancy. In any case please consult your own attending physician before making the session.
- Do not expose yourself to UV immediately after hair removal treatments.
- Consult the physician if on the skin swellings, ulceration's or red spots appear.

**ATTENTION!**

- **Ultraviolet radiation may cause injury to the eyes and skin, such as skin aging and eventually skin cancer.**
- **Read instructions carefully.**
- **Wear the protective goggles provided.**
- **Certain medicines and cosmetics may increase photosensitivity. You should not use undergo tanning treatments if you are taking drugs that may cause photosensitivity.**

A copy of the following warnings is supplied with the manuals and must be shown to the public in close proximity to the unit.

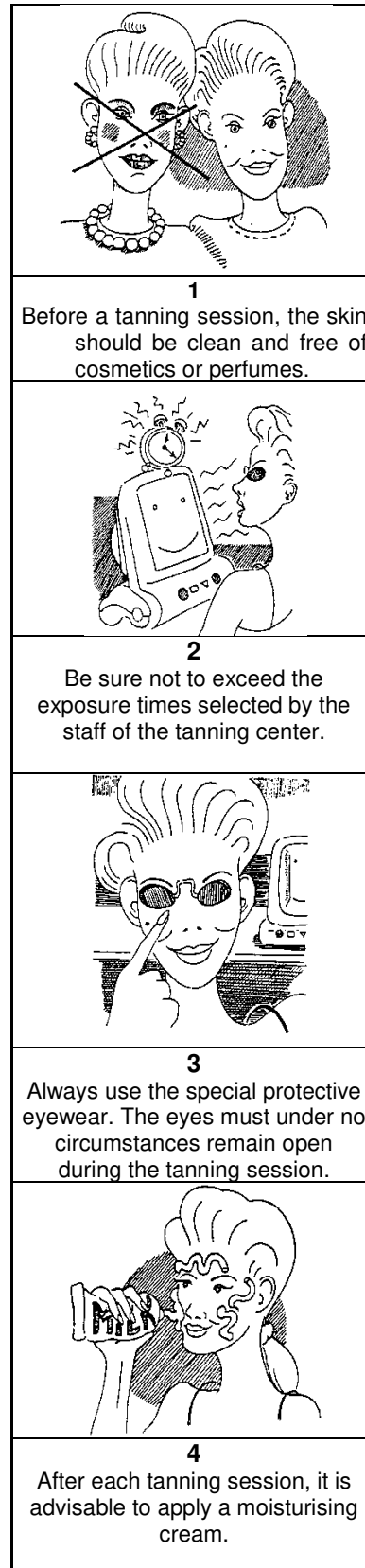

## MEDICATION

Certain drugs can make your skin sensitive to ultraviolet light. The U.S. Department of Health and Human Services has published a booklet entitled Medications That Increase Sensitivity to Light; A 1990 Listing prepared by Jerome: Levine, M.S., R.Ph: The booklet is HHS Publication FDA 91-8280 and is available from the U.S. Government Printing Office: Refer to this booklet or your health practitioner if you are taking any medications.

Dr. Richard Childers and Dr. Edward Emmett of Johns Hopkins University compiled a list of drugs, foods, and other substances that could make your skin sensitive to ultraviolet light: This list is presented below:

- Diuretics (which help prevent water retention), prescribed for high blood pressure (for example, Hydrodiuril).
- Diabetes drugs-Orinase and Diabinase.
- Urinary tract infection treatments with phenothiazines.
- Tranquilizers, such as Thorazine.
- The acne treatment Retin-A.
- Antihistamines-Phenergan and Benadryl-particularly when they are used on the skin in ointment form.
- Antibiotics-Declomycin, Aureozicin, and Griseofulvin, which is use in ringworm treatment.
- Coal tar treatment for psoriasis or chronic eczema.
- Bacterial infection treatments using sulfanilamide.
- Compounds known as furocoumarins or psoralens, which sensitise skin to sunlight whether put on the skin or taken orally. They are prescribed for vitiligo (loss of skin pigmentation) and psoriasis.
- Birth control pills. The hormones they contain can react with sunlight and in some cases cause brown patches on the skin.
- Perfumes and colognes containing furocoumarins, compounds from natural products such as plants and fruits. Their natural oils cad sensitise the skin to sunlight.
- Food and fruits that contain photosensitising agents: celery, carrots, limes, coriander, parsley, fennel, dill, buttercup, mustard and figs.



## 1.6 TRANSPORT AND HANDLING

The machine is carefully protected and loaded onto pallets before shipping. The various parts of the machine must never be transported or stored in positions which differ from the positions in which they are shipped. In this case, the warranty shall be null and void.

The machine must be handled with care in order to prevent the risk of damage to the packaged sections. All handling operations should be carried out by authorized and trained personnel. When the machine is delivered, immediately check that the packaging material is whole and that no damage has occurred during transport.

Any damage to the machine must be notified to the carrier no later than **eight calendar days** from the date of delivery. If internal damage is suspected, it is advisable to accept the machine reserving the right to check accordingly.

**THE CARRIER IS RESPONSIBLE FOR ANY DAMAGE OCCURRING DURING TRANSPORT OF THE MACHINE. SPORTARREDO WILL MAKE EVERY EFFORT TO ASSIST THE CLIENT IN SUCH CASES**

**ALL MAINTENANCE OF THE MACHINE MUST BE PERFORMED BY SPECIALIZED TECHNICIANS FROM SPORTARREDO OR BY PERSONS AUTHORIZED BY SPORTARREDO USA INC.**

**IMPORTANT!  
ALWAYS DISCONNECT THE MACHINE FROM THE POWER SUPPLY BY PRESSING THE SWITCH BREAKER BEFORE PERFORMING MAINTENANCE**

## 1.7 PREPARATION FOR INSTALLATION BY THE CLIENT

Unless otherwise expressly specified in the contract, the following must be provided by the client:

- Connections to the electrical circuit, including the protective wire generally referred to as the "GROUND CONNECTION", unit feeding cable, power plug and circuit breaker.
- Exhaust pipe system for reducing the hot air.
- External air intake.
- All tools and equipment necessary for installation.

**THE UNIT IS SUPPLIED FOR INPUT VOLTAGE AT 230V 3phase 60 Hz AND IT IS SUPPLIED WITH OUT THE FEEDING CABLE**

*To make a power cable connection or voltage-change, make reference to the chapter "INSTALLATION" paragraph "VOLTAGE CHANGE" and to the HPO EXOTIC n° 1/11 electrical diagram.*

**These operations must be done by technical personnel.**

THE BREAKER MUST BE INSTALLED IN THE POWER SUPPLY BOARD OF THE ESTHETICAL SITE AND IT MUST BE DONE BY THE SITE ITSELF. Mod. HPO EXOTIC:

3x70A-30mA to feed 230V - 3phase ~ 60Hz

**The installation must be done by technical personnel.**

THE POWER SUPPLY CONNECTION (UNIT-BOARD) MUST BE DONE BY THE SALON. THE SKILLED TECHNICIAN MUST USE A CERTIFIED CABLE WITH THE PROPER SECTION AND WITH ADEQUATE MECHANICAL PROTECTION, IN ACCORDANCE WITH THE RULES IN FORCE.

*SEE CHAPTER 3.1 TABLES FOR TECHNICAL DATA "POWER SUPPLY CABLE SECTION"*

PLEASE CONTACT CUSTOMER SERVICE FOR ANY FURTHER CONCERNS:

0039-0421-767676

**Before the evening closing, or the closing for a prolonged period you should operate on the breaker in order to disconnect the power supply.**

TO ENSURE CORRECT USE OF THE EQUIPMENT, THE ROOM TEMPERATURE **MUST NOT EXCEED 86°F DEGREES**. IF ROOM TEMPERATURE EXCEEDS THIS VALUE, WE SUGGEST UTILIZING AN AIR CONDITIONING UNIT.

## 2 - SAFETY INFORMATION

### 2.1 GENERAL

The employer must ensure that the persons assigned to the operation of the machine receive adequate training concerning possible accident risks, that the device is checked for the safety of the operator and the client, the risks associated with the emission of UV light and the general accident-prevention regulations specified by international norms and local legislation.

Those responsible for operation, maintenance, cleaning and control of the machine must adhere strictly to the accident-prevention regulations applicable in the country in which the machine is installed.

Before operating the machine, the operator must be familiar with the location and the function of all the controls and with the characteristics of the machine. The operator must read this manual carefully and completely.

The machine must be operated by fully-qualified operators only.

Removal of the safety devices and protective barriers is strictly prohibited.

No heavy weights must be placed on the moving parts of the machine. The ventilation ducts and intake grills must not be obstructed by foreign objects.

The machine must always be switched off and disconnected from the power supply before performing any routine or special maintenance operations.

Unauthorized replacement of or repairs to any part or section of the machine, or the use of accessories or material that are not original or recommended by the manufacturer, may result in injury, and exonerate the manufacturer from all civil or penal liability.

It is prohibited to stay near the appliance while it is operating without eye protection.

**"DANGEROUS ZONES"**: any zone inside or in the vicinity of the machine in which the presence of an exposed person constitutes a risk for the safety and the health of that person.

**"EXPOSED PERSON"**: any person who is wholly or partially in a dangerous zone.

**"OPERATOR"**: person or persons assigned to the installation, operation, adjustment, maintenance, cleaning, repair and transport of the machine.

### 2.2 NOISE

The machine is designed and built in such a way as to reduce operational noise as follows:

Effective normalized sound power during operation, see diagram below:

**1 - 2 - 3 - 4 - = 77 dB (A) max.**

Effective sound pressure with simulation of the actual position of the person being treated:

**A = 79 dB (A) max.**

**The figures shown above have been determined according to ISO 3746.**

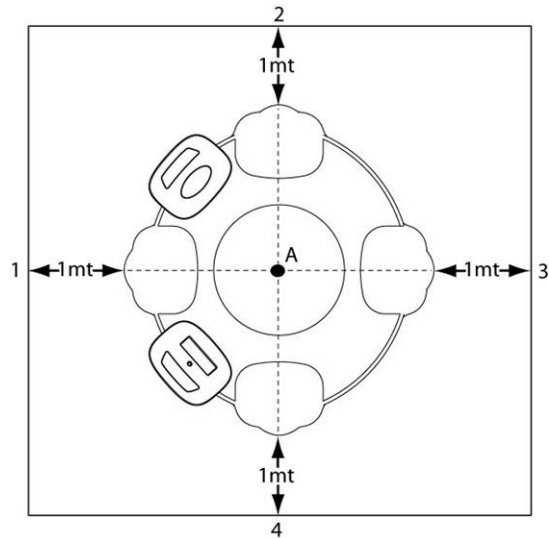

### 2.3 REGULATIONS

**Standards for safety of Luminaires, UL 1598 - 1<sup>st</sup> Ed. & CSA C22.2 No.250.0-00.**

In the planning of this unit the following rules and provisions of the European Community have been taken into consideration:

**ECC Directive 2014/35** known as "low voltage directive".

**ECC Directive 2014/30** known as "Electronic compatibility directive".

**EN 60335-1**, "Safety of electrical appliances for domestic and similar use. Part I: General rules"

**EN 60335-2-27 part II**, Special standard for units for the treatment of the skin with ultraviolet and infrared rays for home use and similar use.

### 3 - TECHNICAL DATA

#### 3.1 DIMENSIONS AND TECHNICAL DATA

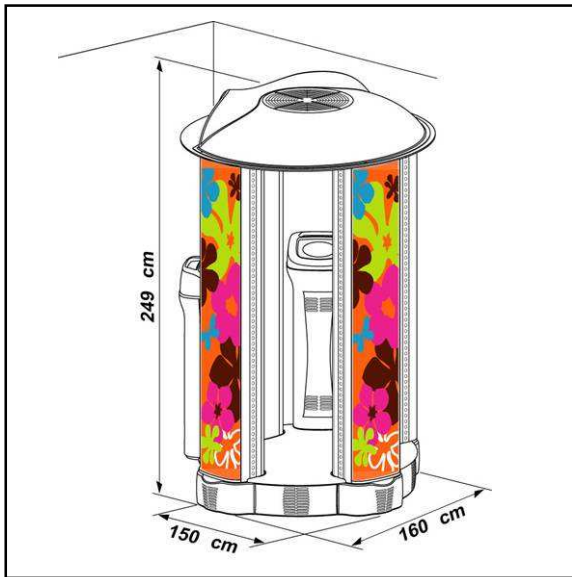

HEIGHT	249 cm	98 in
LENGTH	160 cm	63 in
WIDTH	150 cm	59 in
WEIGHT	560 Kg	1301 lb

HPO EXOTIC	U.M	DATA
POWER SUPPLY	V	230V 3ph (230V 1ph)
NOMINAL POWER	KW	21.3
NOMINAL CURRENT	A	54.7 (91)
FREQUENCY	Hz	60
WIRE SIZES	AWG	5 (2)
NUMBER OF WIRE REQUIRED		4 (3)
EXHAUST AIR FLOW	m³/h	2x1060
EXAUST FAN PRESSURE	Pa	0÷200
HEAT PRODUCED	Kcal/h	17500
HEAT EXPELLED	Kcal/h	10500
LAMPS TYPE	N.	5 KALFASUN 1530F 23x KALFASUN 630F
THERMIC PROTECTION 120°C		

#### UV EMISSION

SEE RAY EMISSION CERTIFICATE

### 4 - INSTALLATION

#### 4.1 PRE-INSTALLATION

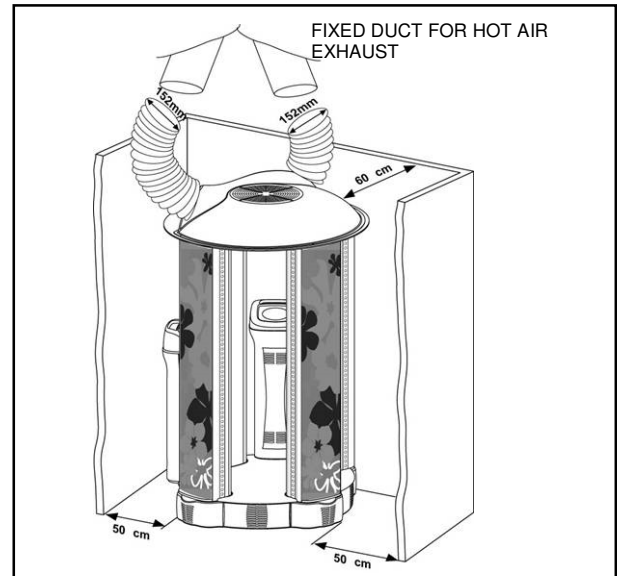

In order to ensure correct operation of the machine, it should be installed in an area which has been prepared as shown in the figure.

The connection of the exhaust air pipe must have on the first part (50-60 cm / 19"-23" inch from the edge of the fan) the minimum curving. This device has to be done to reduce the noise of the fan caused by the resistance of the hair, to improve the cooling of the lamps and to have a better air flow during the tanning session.

#### 4.2 CONNECTION

The area in which the machine is installed **must be adequately ventilated. Supply the area with an air intake from outside if necessary.** To improve the technical comfort, connect the tube to expel the hot air to a fixed duct to expel the air outward

- The metal structure of the machine is grounded by means of insulated wires connected to the ground terminal in the electrical junction box.
- The ground circuit must be in full compliance in accordance with the rules in force.
- The ground connection must also be fitted to low-voltage systems situated in wet or very damp areas (if the voltage to ground is in excess of 25V for alternating current or 50V for direct current).
- The ground wires connected to every part of the various sections of the machine and the ground wires from the various power circuits and user groups must be connected to a single grounding circuit.
- Ensure that the materials used for the grounding system are suitably robust and provided with adequate protection.
- The connection to the main ground terminal should be as short as possible. The ground wires should not be subjected to mechanical stress of any kind, and must be protected against corrosion.

### 4.3 ASSEMBLY INSTRUCTIONS

#### SEE TABLES AND PHOTOS ENCLOSED

- 1 - Put the ballast cassette (marked with **1-2-3-4**) like shown in Table 1.  
Join the ballast cassette with 6x20 hexagonal screws.  
Insert the four fans in the provided clamps and fix them with 2 screws 4.8x9.5 large head. See Table 1.
- 2 - Insert the column **A** (radio column) and column **B** (control board column) without the cover plastics with 6x20 hexagonal screws like shown in Table 2.  
Connect the following connectors:
  - **1** connector with long cable (16-poles male from **B** column) with connector **1** (16-poles female in to **A** column).
  - Under the column **1**: connector **2** (3-poles black from **A** column) with connector **2** (3-poles black from **B** column).
  - From **A** column (radio) to **1** column connect the red-black plug.
  - From **A** column (radio) to **B** column (control board) connect white connectors.
  - From **A** column (radio) spiral connector **3** (16-poles) to ballast cassette nr. **4**.
  - From **A** column (radio) connector **4** (16-poles) to ballast cassette nr. **3**.
  - From **B** column (control board) spiral connector **5** (16-poles) to ballast cassette nr. **1**.
  - From **B** column (control board) connector **6** (16-poles) to ballasts cassette nr. **2**.

The cables of connectors were inserted in the specific clamps with the rubber cable-passage. See photos 1-2.
- 3 - Put the lamps columns without acrylics with 4 screws 6x20 hexagonal head without tighten. The columns are marked with **1-2-3-4** following the indications reported on the Table 2.
  - **1** face column.
  - **2-3-4** column with silkscreen printing HPO EXOTIC.

Connect the black fans connectors 5-poles and the 16-poles connectors to the columns.  
Insert the internal acrylics and fix in up side with the screws to rapid release. See Table 8.
- 4 - Put the white teflon circle and fix it without tighten in every columns with screws 6x20 to hexagonal head and with an teflon washer. See Table 3.
- 5 - Install the fans upper section following the number indications (**1-2-3-4**) and fix it in every column with 2 screws 6x20 hexagonal head. See Table 3.  
Connect the following connectors:
  - Black connector 7-polig from face column 1 to canopy;
  - Connecting the loudspeakers.
  - Black connector 3-polig and black connector 2-polig.
- 6 - Insert the handle in the specific hole in the canopy teflon and fix it using a metallic bracket. See Table 4.
- 7 - Center the teflon circle and stop it with an 6x20 screw in every columns. Tighten afterwards all the columns screws.
- 8 - Connect the feeding cable to **B** column. See photos 3- 4.
- 9 - Insert the green foot-board and fix them with the central 6x20 hexagonal screw.
- 10 - Insert the external acrylics and fix in up side panel with the screws to rapid release. See Table 8.  
Install the plastic cover columns **A** (radio) and **B** (control board) and canopy fixing it with the 3.9x9.5 and 3.9x19 screws. See Table 5.  
Install the plastic cover of canopy with 4 black screws 6x20 TCEI.
- 11 - Install the plastic covers on the base with 4x20 screws and 4x12 washer. Apply the remaining covers with the magnetic closing. See Table 6.
- 12 - Insert the orange gel foot-board.

#### WARNING!

**In the control box there is a safety timer set this timer at a value 10% longer than the maximum session time.**

**e.g.: session time 15 min set the safety timer to 16.5 min.**





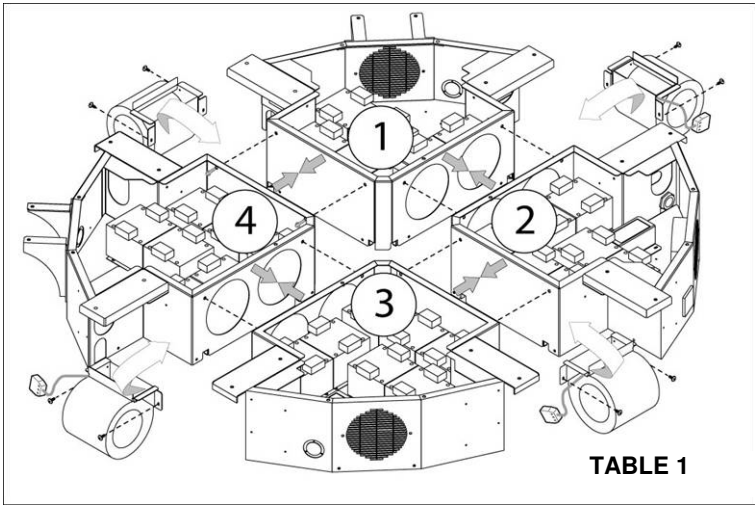
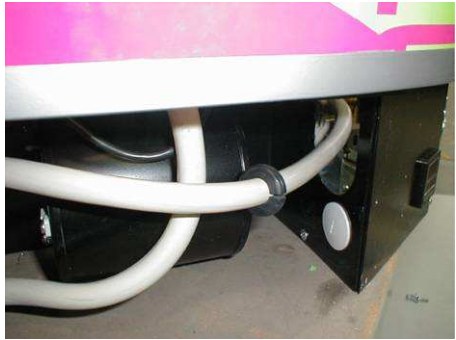

TABLE 1

1



2



3



4

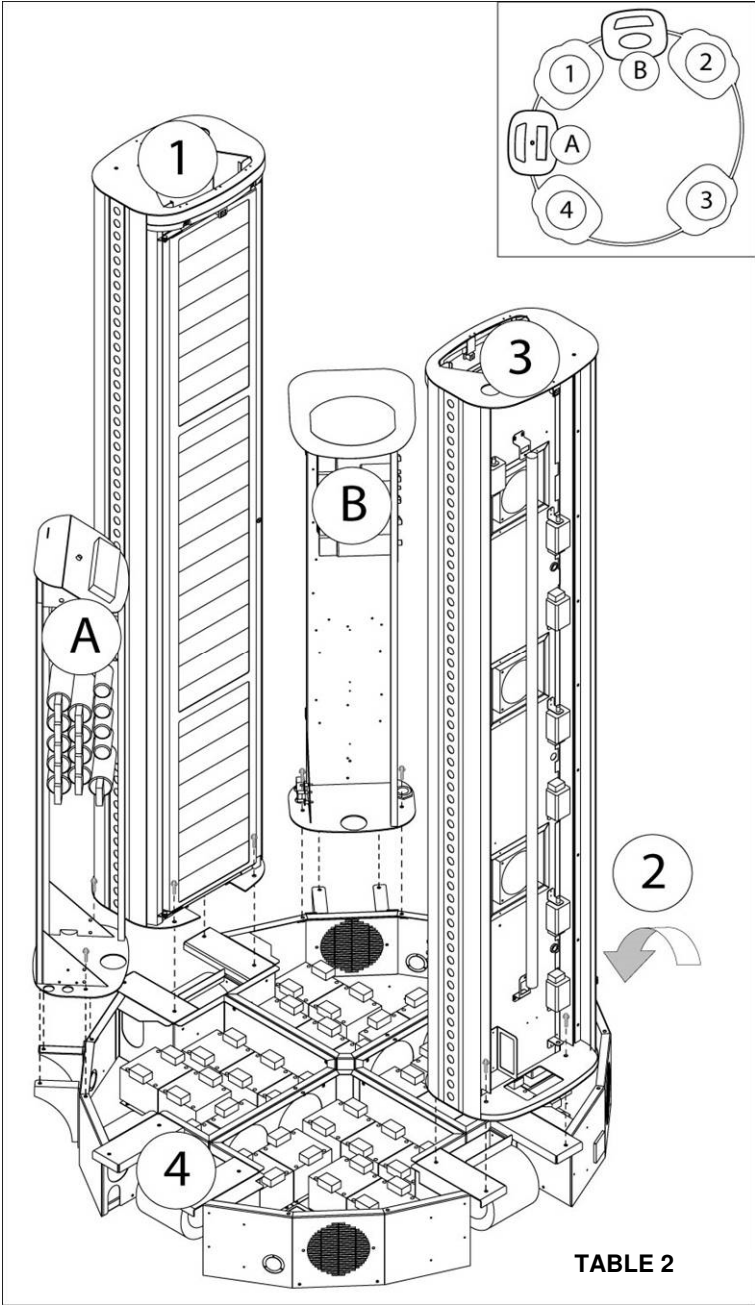
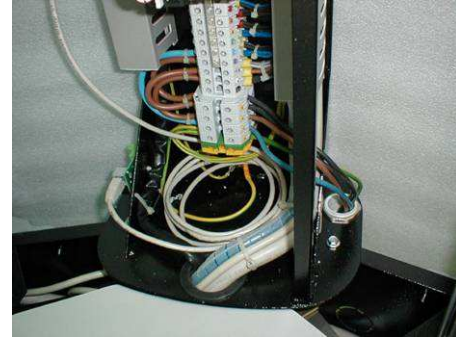
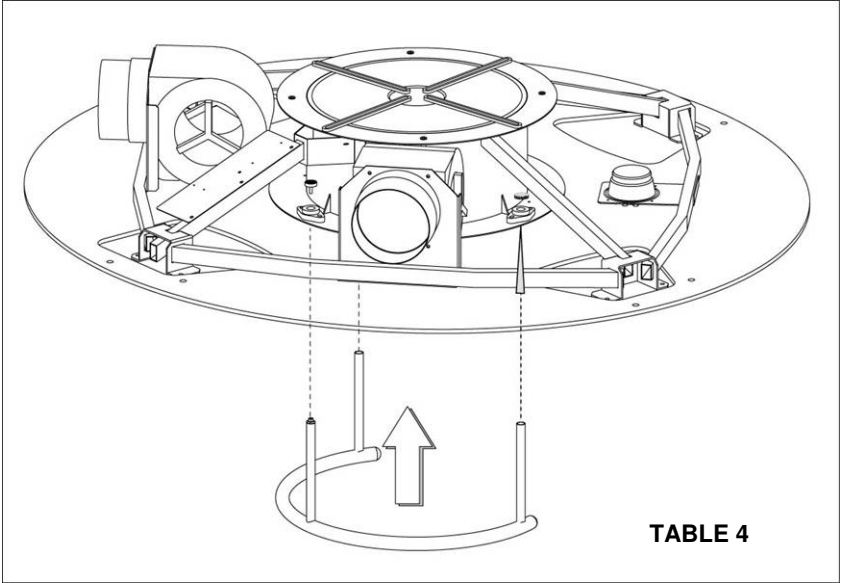
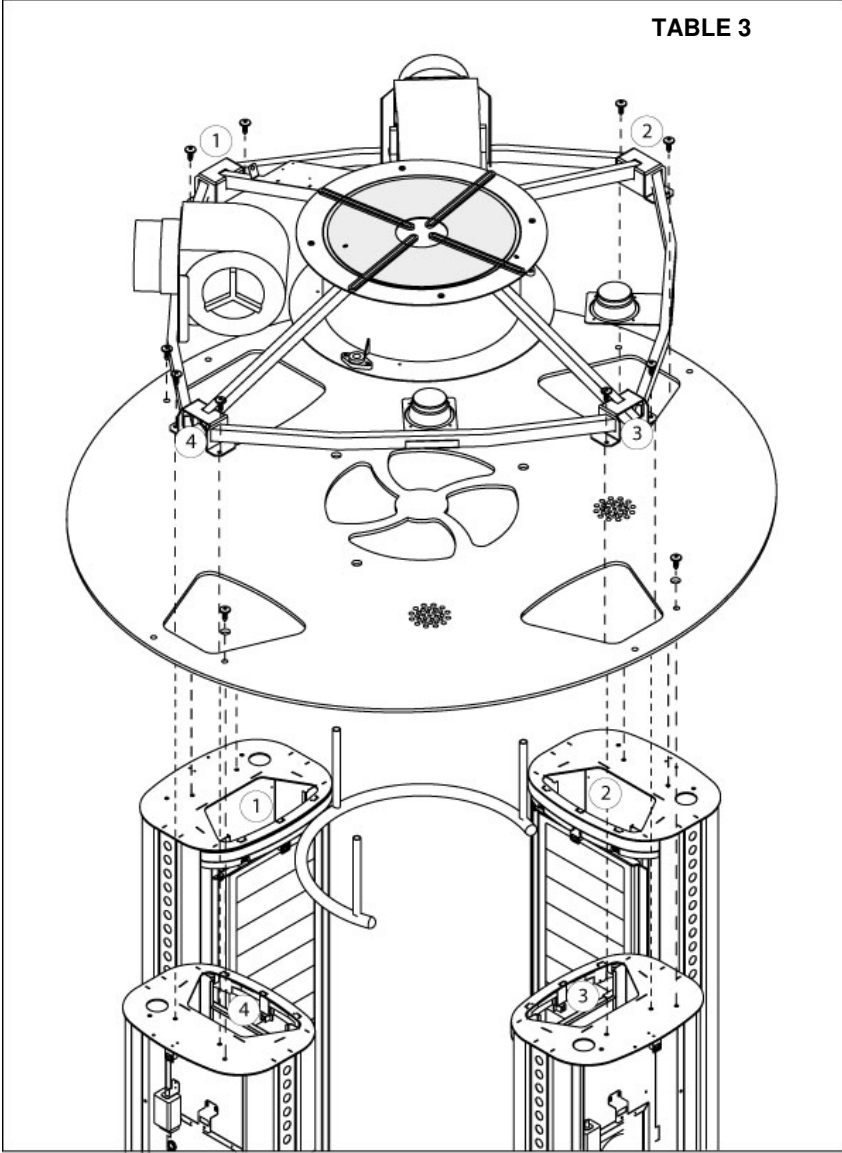
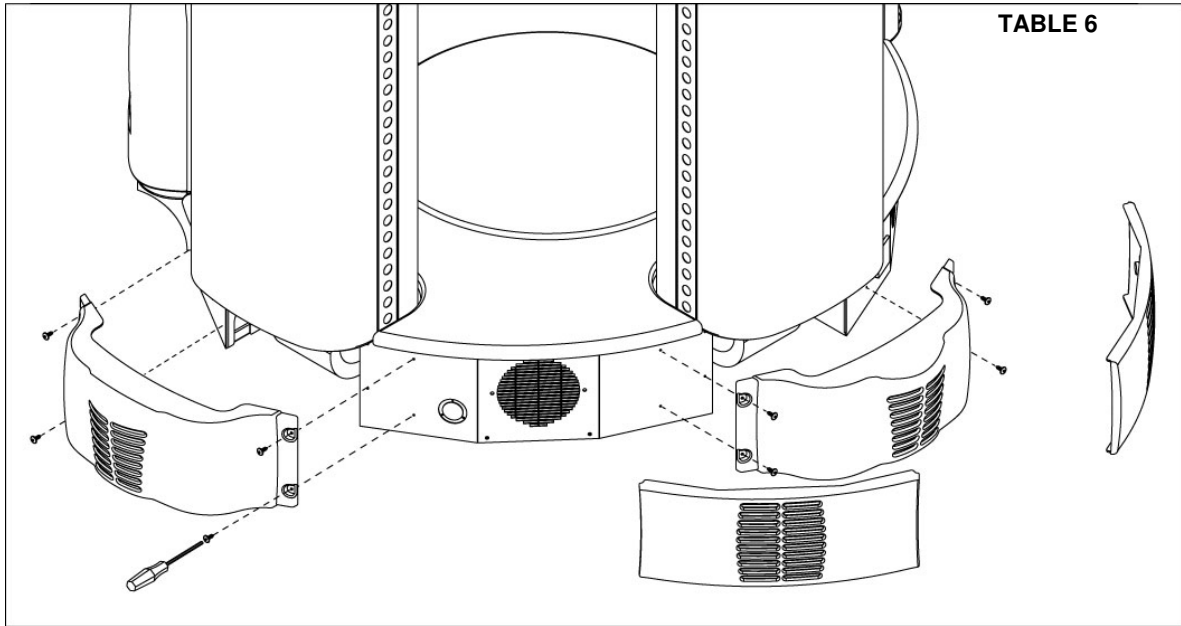
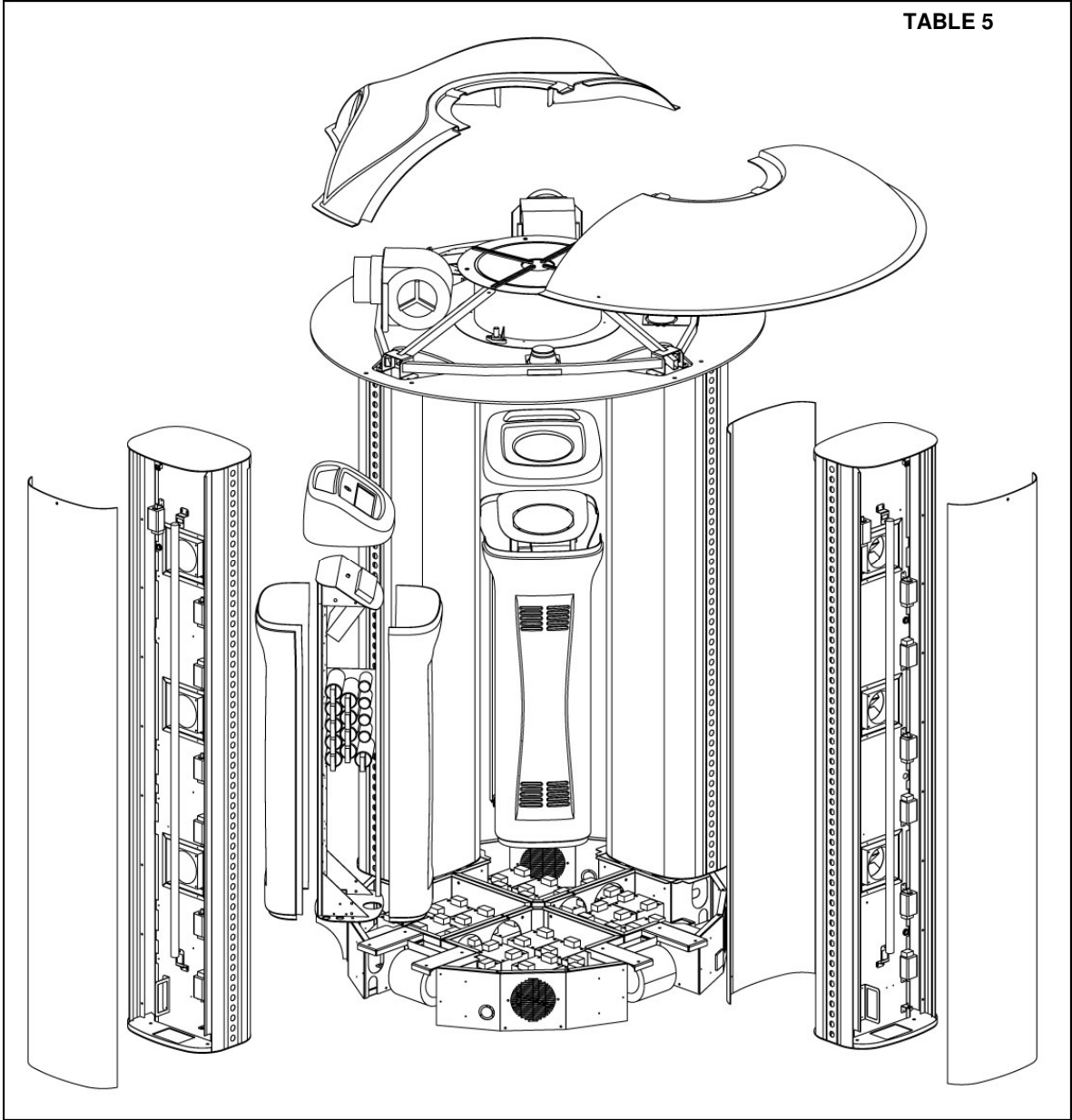

TABLE 2







#### 4.4 VOLTAGE CHANGE

For the main terminal blocks inside the main control board column B, please refer to the pictures 3 and 4 and the Table 7 on this page.

**IMPORTANT!**  
**ALWAYS DISCONNECT THE MACHINE**  
**FROM THE POWER SUPPLY BY**  
**PRESSING THE SWITCH BREAKER**  
**BEFORE PERFORMING**  
**MAINTENANCE**

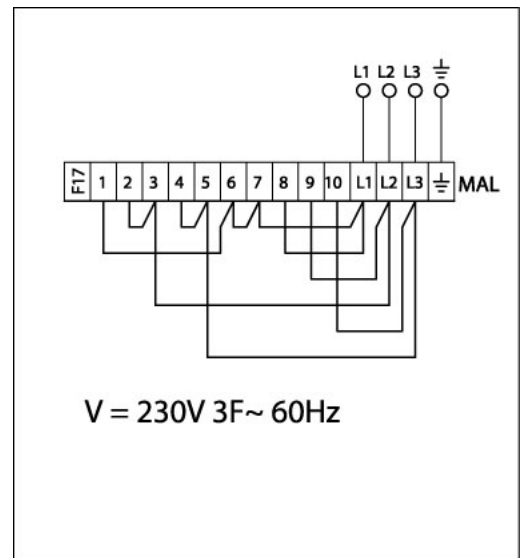
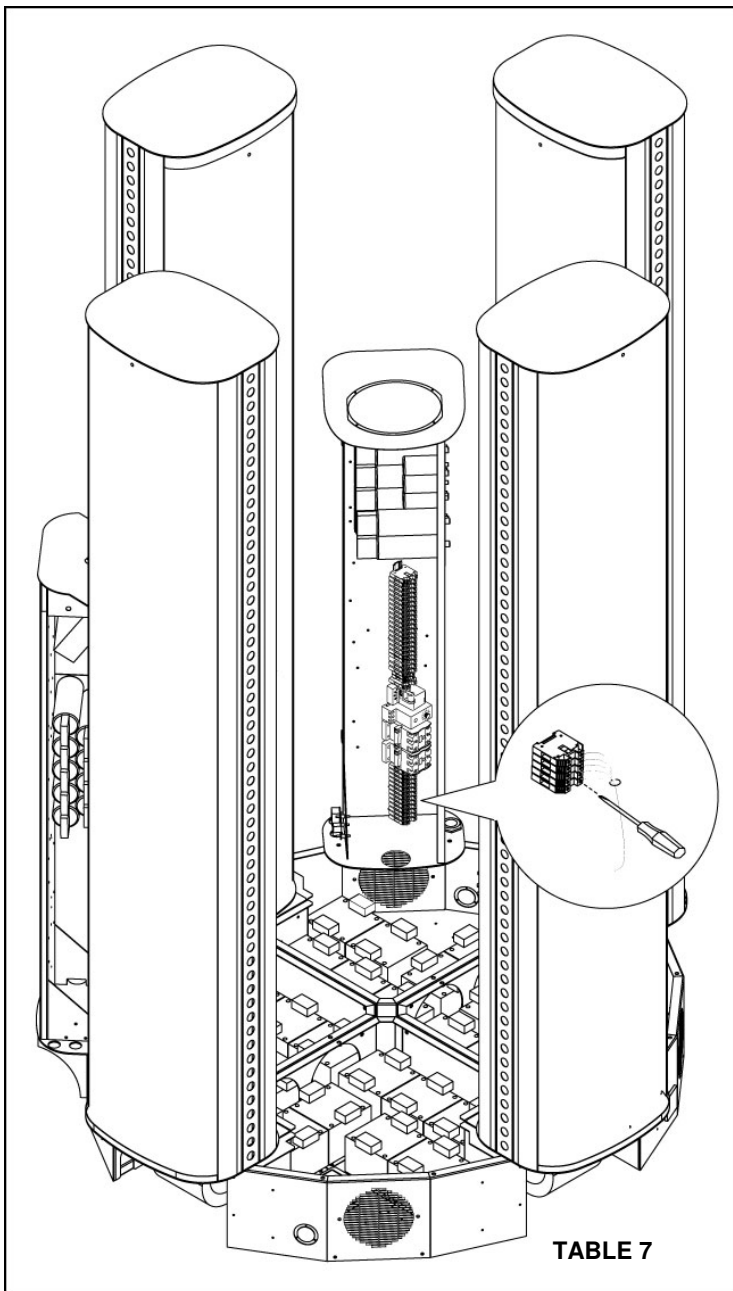

## 5 - USE

## 5.1 CONTROL BOARD

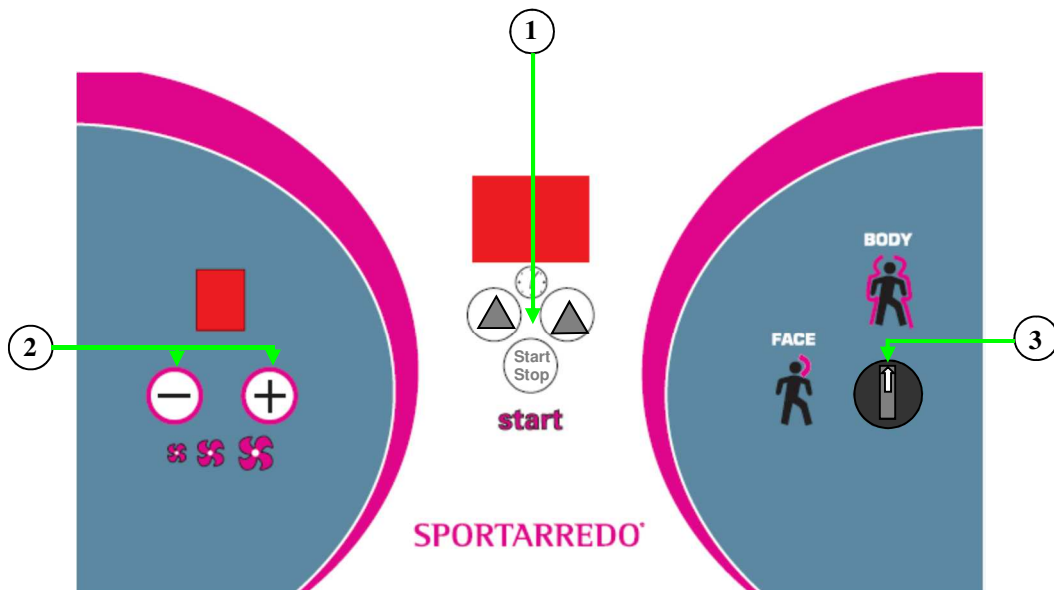

## 1. TIMER BOARD T-MAX® 005 OVERVIEW

Each T-Max® 005 can manually control a tanning bed, connected to a T-Max® 3A remote front desk control or be connected with many T-Max® timers and a T-Max® Manager or T-Max® Manager/Pro to control many beds from a remote location.

Operation is accomplished via front panel controls.  
(Refer to Paragraph 8).

**May be used by authorized personnel only.**

## 2. BODY VENTILATION

+/-: increases or decrease the body ventilation.

## 3. SELECTOR:

FACE – Switches on the facial lamps and switches off the body lamps

BODY – Switches on all the lamps.

Selection of the lamps must be made by the qualified personnel of the tanning centre and must be set before the session

## 6 - MAINTENANCE PERFORMED BY THE CUSTOMER

### 6.1 CUSTOMER MAINTENANCE

(Refer to Paragraph 8 Section 6.1)

- Cleaning of cobalt and transparent filters)

**IMPORTANT!**  
**ALWAYS DISCONNECT THE MACHINE FROM THE POWER SUPPLY BY PRESSING THE BREAKER SWITCH BEFORE PERFORMING MAINTENANCE**

### REMOVING AND CLEANING THE ACRYLIC PANEL AND BLUE COBALT FILTER

To clean the acrylic and the columns cobalt filters it is necessary to follow instructions on Table 8.

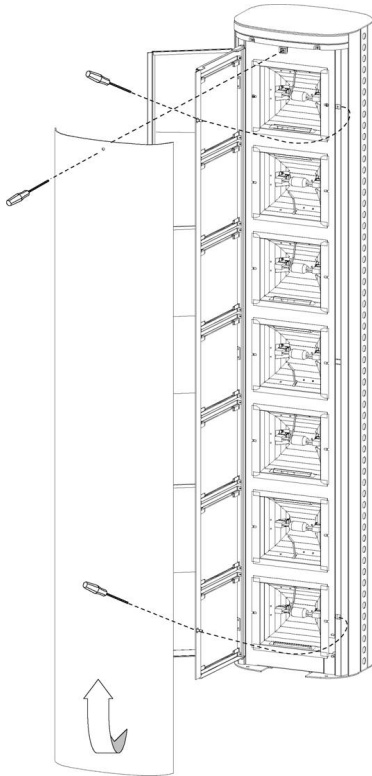

TABLE 8

### CHECK OF THE BLUE COBALT FILTER

To prevent exposure to harmful rays it is important to check the good conditions of the blue cobalt filters and the fixing condition to the metallic frame. If breaks or cracks are present in a blue cobalt filter, a security device automatically switches off the unit. The feeding switches on again when the blue cobalt filter is replaced.

**These checks must be performed by qualified personnel.**

### CLEANING THE TRANSPARENT AND BLUE COBALT FILTERS

Clean the filters internally and externally using the suggested disinfectant solution.

**ANY TAMPERING WITH THE APPLIANCE OR THE USE OF NON-ORIGINAL MATERIAL OR PARTS MAY LEAD TO INJURY. IN SUCH CASES, THE MANUFACTURER DECLINES ALL CIVIL AND PENAL LIABILITY, AND THE WARRANTY SHALL AUTOMATICALLY BE CONSIDERED NULL AND VOID.**

### REFLECTORS USED IN THIS APPLIANCE:

5xHPO 1530T LM

23xKF630 LM

### CLEANING INSTRUCTIONS FOR SUNTAN BED'S SURFACES

Wipe gloved hands and use cleaning supplies, for example: a low-shedding wipe and Destacryl Ultra by Cosmedico cleaner/disinfectant product and start to clean the interior of the device.

Using the wipes with the Destacryl cleaner/disinfectant product, wipe the bench surface or the internal of the booth from side to side.

Wipe in overlapping parallel strokes. Overlap each stroke by 10-24 percent and present a clean quarter-folded wipe surface with each stroke.

Wipe all surfaces including the pass through door, handle and footplate, if present. Note: If the interior of the equipment was physically clean before the application of the Destacryl cleaner/disinfectant, then the surfaces contacted will have been properly disinfected. If the surfaces were not physically clean at the beginning, steps 3 to 6 should be repeated since the first wipe-down may have only removed physical dirt and not effectively reduced the bioburden to within the acceptable limits.

Ensure all surfaces being in contact with a person has been cleaned.

Wipe gloved hands again with the Destacryl cleaner/disinfectant product and start cleaning the exterior of the device.

Using the Destacryl cleaning/disinfectant product, begin by cleaning the ceiling of the tanning bed or booth from side to side and then the lateral surfaces from top to bottom. Each cleaning tool pad should be changed as soon as it appears unclean or no longer wets the contact area. Ensure all surfaces are thoroughly wet with the Destacryl cleaner/disinfectant product.

Place all soiled wipes, covers and cleaning supplies into a disposal bag and remove from the room where the device is located.

For air filter (if present): Open the external grid and remove the air filter. Then use compressed air or water to clean the air filter. Be sure that the air filter is dry before to replace it on its position and start a new session.

**IMPORTANT:** Allow surfaces to dry before the beginning of another session. Some surfaces, such as acrylic, may be damaged by exposure to 70% isopropyl alcohol (IPA) over time. Cause this case, a non-residue generating cleaner/disinfectant product like the Destacryl by Cosmedico applied to non-shedding dry cleaning pads and wipes may be used instead.

**NOTE:** This document is for guidance only and should be used with reference to the equipment manufacturer's instructions for use and existing standard operating procedures for the facility.



6.2 RECOMMENDED REPLACEMENT AND  
OBTAINING REPAIRS

## SPARE PARTS LIST

REF	PC	CODE	DESCRIPTION
1	5	4028.4400.03	1500W HP LAMP IGNITOR
2	23	4028.4400.04	600W HP LAMP IGNITOR
3	3	4028.1002.06	MEC 58W BALLAST FOR ACCESSORY LIGHT
4	1	4028.1003.04	12V TRANSFORMER FOR T.MAX AND RADIO
5	5	16973.001.0.0	1500W HP LAMP BALLAST
6	23	16973.000.0.0	600W HP LAMP BALLAST
7	2	4027.3030.04	LOUDSPEAKER
8	1	4027.3028.01	ANTENNA
9	4	4028.4310.00	COMPASSADOR 2,5µF
10	12	4028.4304.00	COMPASSADOR 20µF
11	1	4028.4307.03	COMPASSADOR 5µF
12	16	4028.4300.00	COMPASSADOR 65µF
13	1	4028.6000.01	REVALCO HOUR COUNTER
14	1	4028.2100.10	FANTINI&COSMI HR 46 CONTACTOR FOR BODY LAMPS
15	1	4028.2100.04	FANTINI&COSMI HR 1710 CONTACTOR FOR VENTILATION
16	1	4028.2100.06	FANTINI&COSMI HR 2510 CONTACTOR HP FACIAL LAMPS
17	28	16976.064.0.0	COBALT GLASS FILTER
18	3	16976.058.0.0	CLEAR GLASS FILTER ULTRALUX 26x24
19	3	16976.003.0.0	CLEAR GLASS FILTER SUPERLUX TR-T 24x21
20	16	4028.3127.07	10,3x38 - 15A FUSE FOR HP LAMP
21	1	4028.3125.06	5x20 6,3A FUSE FOR ACCESSORY LIGHT AND RADIO
22	1	4028.3126.12	5x20 2,5A FUSE FOR VOCAL BOARD
23	5	4028.4002.01	KALFASUN 1530W HP LAMP
24	23	4028.4002.00	KALFASUN 630W HP LAMP
25	3	4028.4013.12	58W ACCESSORY LIGHT
26	1	15920.067.0.0	HANDLE
27	5	14073.049.0.0	HPO EXOTIC1530T L REFLECTOR
28	23	14073.048.0.0	KF630 L REFLECTOR
29	1	16916.096.0.0	FOOTBOARD RIGHT
30	1	16916.093.0.0	FOOTBOARD LEFT
31	1	16916.091.0.0	ORANGE GEL FOOTBOARD???
32	1	16916.102.0.0	ORANGE FOOT PAD
33	4	16916.081.0.0	INTERNAL COLUMN ACRYLIC
34	4	16916.092.0.0	EXTERNAL COLUMN ACRYLIC FLOWERS
35	1	16916.083.1.0	TOP ACRYLIC
36	1	4027.3025.08	RADIO/CD/MP3
37	1	4028.2185.07	FACIAL SWITCH"DECA"
38	1	15906.026.0.0	ELECTRONIC BOARD FOR HEADSET JACK
39	1	4026.0021.00	T.MAX® 005 CONTROL BOARD
40	1	15906.067.0.0	DMD-1 VENTILATION BOARD
41	1	15906.076.0.0	MAIN CONTROL BOARD KEYPAD
42	1	4028.2116.04	TIMER OMRON

43	1	4028.2140.02	HEAT SENSOR 120C
44	1	4028.0033.00	EBM A4E400-AA06-02 BODY FAN
45	5	4028.0021.00	EBM W2S/ 130 AA0301 HP 1500W LAMP FAN
46	4	4028.0050.00	EBM 2GDS15 120X126L BOTTOM COLUMN FAN
47	2	4028.0049.00	EBM D2E 146-HT 67-01 EXHAUST FANFAN
48	9	4028.0052.00	4650N HP 600W LAMP FAN
49	28	4026.1010.04	LIMIT SWITCH
50	1	4028.2102.00	DELAY TIMER IT60D FOR CONNTACTOR
51	4	16946.383.0.0	BOTTOM PLASTIC COVER FOR COLUMN
52	4	16946.384.0.0	BOTTOM FAN PLASTIC COVER
53	2	16946.385.0.0	REAR PLASTIC COVER FOR LITTLE COLUMN
54	2	16946.386.0.0	FRONT PLASTIC COVER FOR LITTLE COLUMN
55	1	16946.387.0.0	TOP PLASTIC COVER FOR CONTROL BOARD COLUMN
56	1	16946.388.0.0	TOP PLASTIC COVER FOR RADIO COLUMN
57	1	16946.389.0.0	TOP FRONT PLASTIC COVER
58	1	16946.333.0.0	TOP REAR PLASTIC COVER

For replacement lamps, eye-wear or parts, contact:

**PC Tan**  
**1040 Wilt Avenue**  
**Ridgefield, NJ 07657**  
**USA**  
**(201) 943-6100**

## 7 - MAINTENANCE PERFORMED BY A SKILLED TECHNICIAN

### 7.1 SKILLED MAINTENANCE

(Refer to Paragraph 8 Section 6.2).

- Clean the internal and external filters.
- Replace high pressure lamps.
- Check that the timer system is working correctly.
- Check that the user instructions are legible and in satisfactory condition.
- Replace the reflectors, the igniters for the high pressure lamps.
- Clean the fans and the inside of the machine.

### 7.2 PERIODIC CONTROL PROCEDURES

**Electrical checks.** Check that the electrical safety devices, and the acoustic/illuminated signal devices and alarms are undamaged and that they function correctly. Check that the equipment and devices in the electrical control box are in satisfactory condition.

**These checks must be performed by qualified personnel.**

**IMPORTANT!**  
**ALWAYS DISCONNECT THE MACHINE**  
**FROM THE POWER SUPPLY BY**  
**PRESSING THE BREAKER BEFORE**  
**PERFORMING MAINTENANCE**

**IMPORTANT!**  
**USE ONLY THE SUGGESTED DISINFECTANT FOR**  
**CLEANING THE ACRYLIC AND THE FOOT-BOARD**  
**N.B. DO NOT USE ALCOHOL OR ALCOHOL-BASED**  
**PRODUCTS**

### CHECK OF THE BLUE COBALT FILTER

To prevent exposure to harmful rays it is important to check the good conditions of the blue cobalt filters and the fixing condition to the metallic frame. If breaks or cracks are present in a blue cobalt filter, a security device automatically switches off the unit. The feeding switches on again when the blue cobalt filter is replaced.

**These checks must be performed by qualified personnel.**

### MAINTENANCE OF BLUE COBALT FILTERS

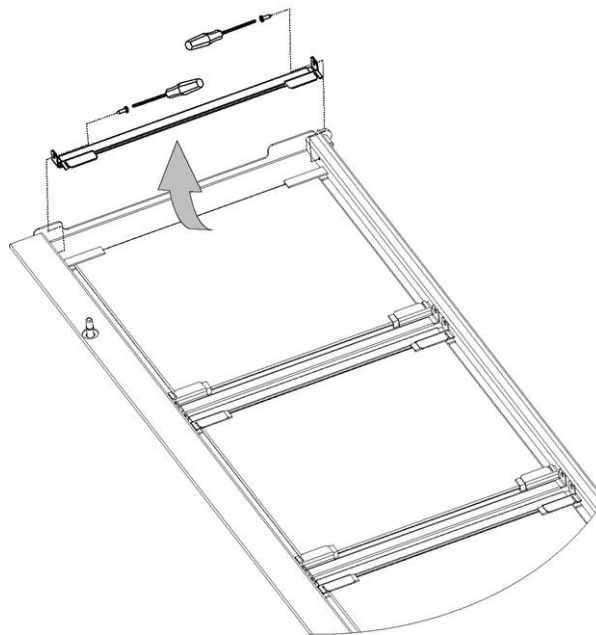

### CLEANING THE BLUE COBALT FILTERS

Clean the filters internally and externally using the suggested disinfectant solution.

**ANY TAMPERING WITH THE APPLIANCE OR**  
**THE USE OF NON-ORIGINAL MATERIAL OR**  
**PARTS MAY LEAD TO INJURY. IN SUCH CASES,**  
**THE MANUFACTURER DECLINES ALL CIVIL**  
**AND PENAL LIABILITY, AND THE WARRANTY**  
**SHALL AUTOMATICALLY BE CONSIDERED**  
**NULL AND VOID.**

## 7.3 THERMAL PROTECTION REFITTING

INSTRUCTIONS FOR THERMAL PROTECTION  
REFITTING

**IMPORTANT!**  
**ALWAYS DISCONNECT THE MACHINE**  
**FROM THE POWER SUPPLY BY**  
**PRESSING THE BREAKER BEFORE**  
**PERFORMING MAINTENANCE**

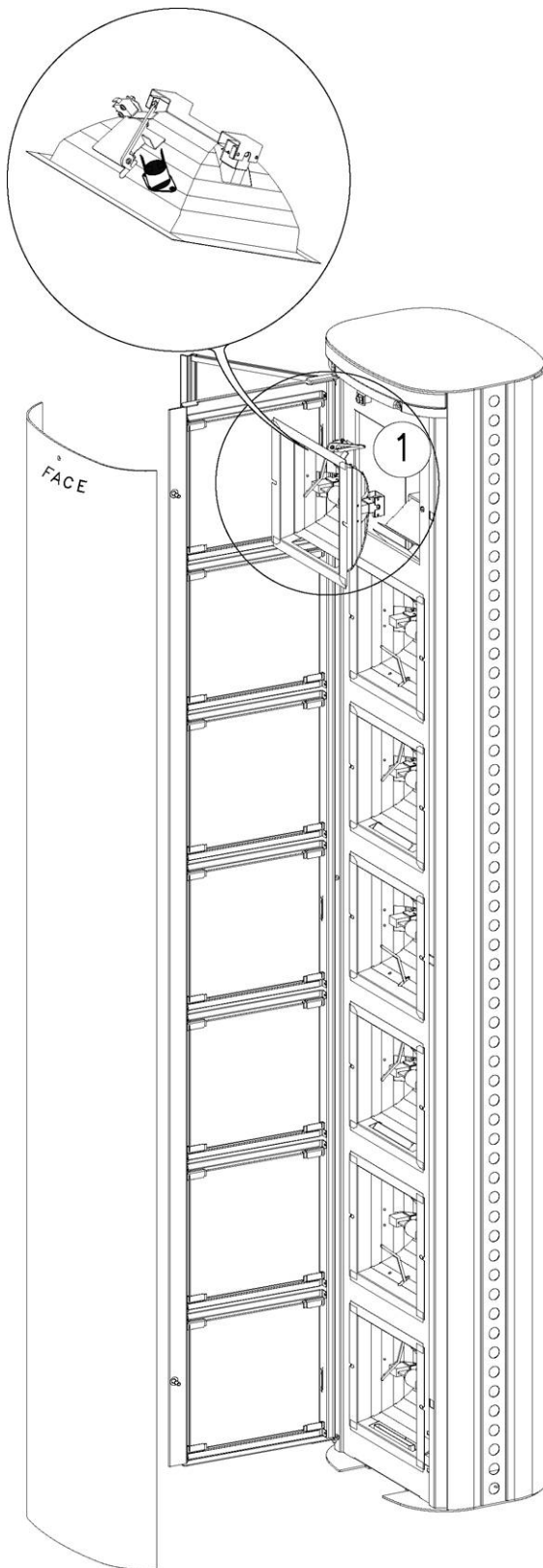

The unit is fitted with a thermal protective component that acts when the security temperature is exceeded. The thermal protective component is placed on the first reflector in to face column (see Table 9). In case of over-heating the protection acts switching off the lamps.

The **PROTECTION IS SELF-RESTORING** that is to say it re-starts automatically when the temperature decreases to a normal value (10/15 minutes depending on the use conditions). After which the unit is ready to start again.

**WARNING!**

Should the thermal protection come into operation, this means that the equipment is functioning incorrectly. Make sure that the air extraction ducts are free or are not insufficiently sized or that the suction filters are not blocked. Inform the specialized technician of the problem.

TABLE 9

## 8 – TIMER BOARD T-MAX® 005

### 8.1 TABLE OF CONTENTS

#### 1 OVERVIEW

##### 1.1 Specifications

#### 2 CONFIGURATION

##### 2.1 Connecting to the tanning bed and applying power

##### 2.2 Setting parameters

##### 2.2.1 Setting the address

##### 2.2.2 Setting delay time

#### 3 USING THE T-MAX® 005 AS A STAND ALONE TIMER

##### 3.1 Starting a session

##### 3.2 Pausing a session

##### 3.3 Cancelling a session

#### 4 REMOTE SINGLE BED CONTROL

##### 4.1 Wiring

##### 4.2 Configuration

##### 4.3 Session control

#### 5 USING THE T-MAX® 005 WITH A T-MAX® MANAGER OR T-MAX® MANAGER/PRO

#### 6 OTHER FEATURES

##### 6.1 Clean room

##### 6.2 Lamp hours

##### 6.3 Connecting the AP900

##### 6.4 Third party interface (TPI) mode

##### 6.5 External speaker

#### 7 FIGURES

##### 7.1 Figure A – Front and rear view of the T-Max® 005

##### 7.2 Figure B – Connecting the T-Max® 3A to a tanning bed with the T-Max® 005

##### 7.3 Figure C – TPI (Third Party Interface)

© COPYRIGHT 1995-2006 BY APPLIED DIGITAL, INC, INC.

The information in these tables of contents are believed to be correct: However, Applied Digital, Inc. assumes no responsibility for any errors herein. This information is subject to change without notice, and should not be construed as a commitment by Applied Digital, Inc.

This product is warranted against defective materials and workmanship for a period of two years from date of purchase. In the event the product fails to perform, it may be returned; Shipping Paid, to the factory to be serviced or replaced at the factory's discretion. Applied Digital, Inc. will pay to ship the repaired or replaced product by the shipping means of our choosing: Returns will not be accepted without a Return Authorization Number assigned by the factory.

Is a condition of Sale that the user of Applied Digital Inc.'s products assumes all risk and responsibility of use and indemnifies Applied Digital Inc. against all damages. Applied Digital, Inc. is not liable for loss of profits, lost savaging, special ,incidental, consequential, indirect or other similar damages arising from breach of warranty, breach of contract, negligence, or other legal action even if Applied Digital, Inc. or its agent has been advised of the possibility of such damage, or for any claim brought against you by another party. This warranty allocates risks of product failure between the purchaser and Applied Digital, Inc. Applied Digital, Inc's hardware pricing reflect this allocation of risk and the limitation of liability contained in this warranty. It is a violation of the stated warranty to cut or modify the provided modular cables supplied with the T-Max® Series Timers. Connecting the T-Max® Series to third party timers not approved by Applied Digital, Inc. also violates the stated warranty. Contact your dealer or Applied Digital, Inc. to determine if your third party timer is approved by Applied Digital, Inc.

**1 OVERVIEW**

Each T-Max® 005 can manually control a tanning bed, connected to a T-Max® 3A remote front desk control or be connected with many T-Max® timers and a T-Max® Manager or T-Max® Manager/Pro to control many beds from a remote location.  
Operation is accomplished via front panel controls.

**1.1 Specifications**

Current draw: 300mA  
Dimensions: Height – 3.5”  
Width – 3.25”  
Depth – 1.5”  
Relays: 220VAC 5A, SPST Form A

**2 CONFIGURATION**

**2.1 Connecting to the tanning bed and applying power**

A white header provides connections for power, lamps and fan. See Figure 1, Section 7.1 for wiring connections on this timer.

**2.2 Setting parameters**

**Note:** If you are using a T-Max® Manager or T-Max® Manager/Pro and multiple T-Max® timers, remove power from the T-Max® Manager or T-Max® Manager/Pro and keep the power removed until all parameter changes are complete.

1) Press and hold the Start/Stop and Up buttons simultaneously until a “.1” is displayed. Release the buttons.  
This is an indication that you are in the parameter mode. The numbers currently displayed represents the parameter number that you can observe or change.

2) Press the Up or the Down Button until the parameter number that you want to observe or change is displayed.

3) Press the Start/Stop Button. The current value for that parameter will be displayed and be flashing.

The T-Max® 005 will show a number with a period illuminated in the lower center of the display. The number shown is the current value for that parameter.

For Lamp, Session Counts, etc. the value displayed can be as high as 9999. To display this value, T-Max® 3A will flash two number-three times, then two number-three times, pause, two number-three times, two number-three times, pause, etc. For example, if you are checking lamp hours (Parameter 6) and the display flashes the numbers 53 three times, then 14 three times, pauses than repeats, then the total lamp hours stored in that T-Max® 005 is 5314.

4) Press the Up and Down Buttons to change the parameter to the desired value.

If you want to clear the value for that parameter, press the Up and Down Buttons at the same time until the display shows “.0”.

5) Press the Start/Stop Button.

The display will show the parameter number you just changed and a solid period in the lower center of the display. You may now change another parameter by pressing the Up or Down buttons until the parameter that you want to change is displayed.

Repeat Steps 2-4 for each parameter you want to change.

6) To exit the Parameter mode and make the T-Max® 005 available for the next session, press and hold the both up and down buttons until the display shows a 0 with no periods displayed.

**Table 1 – Parameter numbers for observing and changing parameters.**

Parameter #	Description	Max #	Default	Notes
1	Address	255	254	Address of T-Max® 005
2	Beep Mode	1	0	User for High Power beds. 0=Alarm only, 1=Alarm and Flip
3	Delay Time	10	0	Delay in minutes stored in the T-Max® 005
4	Current Sense	1	0	For the T-Max® Sentry™ Option. 0=Disabled, 1=Enabled
5	Session Counts	65535	0	Total session counts for T-Max® 005
6	Lamp Hours	65535	0	Bulbs hours for each bed
7	Bed Hours	65535	0	Number of hours a bed is on
8	Manual Session Counts	65535	0	Counts the number of session the Max® 005 has run while in Stand Alone Mode
9	Clean Room	1	1	0=Clean Room Disabled, 1=Enabled
10*	Manual Lockout	1	0	0=Stand Alone Enabled, 1=Disabled
13	Cool Down Mode	10	0	0=Disabled, 1-10=Enabled. Time delay in minutes allowing bed to cool
15	Fixed Session Counts	65535	0	Counts number of sessions ran thought the T-Max® 005. This value cannot be changed at all. Used as point of reference
19	Third Party Interface (TPI) Mode**	1	0	Used for input for timing systems other than the T-Max® Series. Contact closure input. 0=Disabled; 1=Enabled
20	External Speaker	1	0	0=Speaker on T-Max® 005, 1=External speaker will be used
21	Pause Mode	1	0	0=When session is paused, time will continue to count down. 1=When session is paused, session time will stop counting down
22	Auto Bed Shut Off	1	0	For T-Max® Intercom System Only. 0=When timer is called bed will stay on, 1=When timer is called, bed will stuff off automatically
28	Delay Lamps Ventilation	3	0	Setting the parameter to: 2 minutes

\* If Manual Lockout is enabled, the T-Max® 005 cannot operate as a stand alone timer.



## 2.1 Setting the address

**Note:** If you are using a T-Max® 005 as an independent timer, you do not need to set the address.

1) Press and hold the Start/Stop and Up buttons simultaneously T-Max® 005 until a “.1” appears on the display. Release the buttons.

2) Press and release the Start/Stop button. A number will appear on the display and be flashing. A period will be illuminated in the center of the display.

Pressing and holding the Up button will cause the display to count up. Pressing and holding the Down button will cause the display to count down. Once the count reaches 100, the center period will flash rapidly. This is an indication that you are over 99. For example, if the display shows a .2 with the period flashing, this is address 102. The highest the display will count up is 255.

3) Press the Up or the Down Button until the desired address is displayed. When setting the address remember 3 rules:

- a) Set each T-Max® 005 to a unique address.
- b) Do not set any address to 00.
- c) Do not set any address over 100.

4) Once the desired address is displayed, press and release the Start/Stop button. The “.1” will appear on the display. Nothing will flash.

5) To exit, press and hold both the Up and Down buttons together until the period goes away.

## 2.2 Setting Delay time

1) Press and hold the Start/Stop and Up buttons simultaneously on the T-Max® 005 until a “.1” appears on the display. Release the buttons.

2) Press the Up button until “.3” is displayed.

3) Press and release the Start/Stop button. A number will appear on the display and be flashing. A period will be illuminated in the center of the display. This is the current delay time.

4) Press the Up or the Down Button until the desired delay time is displayed. The highest delay time that can be set on the T-Max® 3A is 10 minutes. If you want no delay time, set the display to 0. If you set the Delay Time to 0, the session time will start immediately after the Start/Stop button is pressed.

5) Press the Start/Stop button. The “.3” will appear on the display. Nothing will be flashing.

6) To exit, press and hold both the Up and Down buttons together until the period goes away.

## 3 USING THE T-MAX® 005 AS A STAND ALONE TIMER

### 3.1 Starting a session

1) Press the Up or Down Button on the T-Max® 005 until the desired session time is displayed. If the display shows a 0, and you want to go directly to the maximum time, press the Down button once.

2) Press and release the Start/Stop button to start the session.

If a delay other than 0 is entered, the delay will count down. A period on the lower right corner of the display will flash rapidly. When the session starts, the period will flash at a once per second rate. If the delay is set to 0, the session will start immediately. If you have a delay and want to energize the tanning bed, press the Start/Stop button again.

### 3.2 Pausing a session

To pause the session press the Start/Stop button. The flashing period on the lower right corner of the display will stop flashing and stay illuminated. To restart the session, press the Start/Stop button on the T-Max® 005. The period on the lower right corner of the display will resume flashing.

**Note:** The session time will continue to count down. The display will continue to update and reflect the remaining session time.

### 3.3 Cancelling a session

To cancel a session, press the Start/Stop button to pause the session then press and hold the Up button until the remaining session time shows on the display disappears.

## 4 REMOTE SINGLE BED CONTROL

Remote single bed control is the ability to control a single T-Max® 005 from a remote location. A T-Max® 3A is required for this configuration.

### 4.1 Wiring

Place a T-Max® 3A at the desired remote location. Wire the T-Max® 3A as shown in the T-Max® 3A user's guide. Run the modular cable provided with the T-Max® 3A from the T-Max® 005 in the tanning room to the remote T-Max® 3A.

Connect the modular cable to one of the RJ-22 ports on each T-Max® 3A (it does not matter which port the cable is connected to).

### 4.2 Configuration

Set the address on the T-Max® 005 in the tanning room to “1”, and the address on the T-Max® 3A to “0”.

**Note:** When setting the address on the T-Max® 005, the power to the front desk T-Max® 3A must be off.

User the T-Max® 3A to set the Delay as described in the user's guide. Any delay time set on the T-Max® 005 will be ignored.

### 4.3 Session control

Starting a session.

1) Press the Up or Down Button on the T-Max® 3A until the desired session time is displayed. Time cannot be set from the T-Max® 005 in the room.

2) Press the Start/Stop button on the T-Max® 3A to start the session.

If a delay other than 0 is set, the delay will count down. A period on the lower right corner of the display will flash rapidly. When the session starts, the period will flash at once per second rate. If there is not delay entered, the session will start immediately.

### Pausing during the session

To pause the session press Start/Stop button on the T-Max® 005 in the tanning room. The flashing period on the lower right corner of the display will stop flashing and stay illuminated. To restart the session, press the Start/Stop button on the T-Max® 005. The period will continue flashing. The session cannot be paused from the T-Max® 3A in this configuration.

Note: The session time will be continued to count down. The display will continue to update and reflect the remaining session time.

### Cancelling a session

To cancel a session, press both the Start/Stop and U buttons together on the T-Max® 3A. The session cannot be cancelled from the T-Max® 005 in the tanning room.

## 5 USING THE T-MAX® 005 WITH A T-MAX® MANAGER OR T-MAX® MANAGER/PRO

If you are using T-Max® 005 with a T-Max® Manager or T-Max® Manager/Pro, follow these instructions for proper operations:

1) Set the address on each T-Max® 005 as described in section 2.2.1.

**Note:** If you have completed the auto addressing as described in your T-Max® Manager user's guide, you do not need to address the T-Max® 005 as manually. Skip this step.

**Note 2:** Set each T-Max® 005 to a different address. No T-Max® 005 should be set to address 0.

2) Using T-Max® Modular cables connect the timers in a daisy-chain as shown in the T-Max® Manager User's guide.

**Note:** If you are using AP900s to connect the system wireless, do not run the modular cables. Connect the AP900s to the T-Max® Manager and to the T-Max® 005 as described in Section 6.3 and in the AP900 user's guide.

**Note 2:** Delay is controlled by the T-Max® Manager, T-Max® Manager/Pro or the software you are using if you are using a computer. It is not necessary to set the delay on the T-Max® 3A. Refer to the T-Max® Manager or T-Max® Manager/Pro User's guide for operation.

## 6 OTHER FEATURES

### 6.1 Clean room

Once the session time has elapsed, the display will show two solid periods only. This is an indication that the room needs to be cleaned. To clear the clean room indication, press and hold the Up button on the T-Max® 3A in the tanning room until the two periods disappear and a "0" appears. To disable the clean room feature, set parameter 9 to a 0. (Refer Section 2.2).

### 6.2 Lamp Hour

To check and change Lamp Hours (or any other parameter), refer to Section 2.2.

### 6.3 Connecting the AP900

The AP900 allows you to connect the T-Max® 005 to the T-Max® System without the need to run cables throughout your salon. Connect an AP900 OEM to the RJ-11 modular connector on the T-Max® 005. Mount the AP900 as described in the AP900 user's guide.

### 6.4 Third party interface (TPI) mode

The Third Party Interface (TPI) mode is used for connecting the T-Max® 005 timer to a timing system other than the T-Max® Series.

Pins 3 and 4 on the RJ-22 modular port on the back of the T-Max® 005 are used 005 for TPI. Connect pins 3 and 4 on the top RJ-22 connector to the relay output of your third party interface controller (Refer to Section 7.3. Figure C).

When the session is started, the third party timer will provide a contact closure to the input on the T-Max® 005. When the session is started, the T-Max® 005 will show the maximum time stored into that T-Max® 005 and the tanning bed will turn on. Once the session ends the front desk controller will remove the contact closure from the TPI input on the T-Max® 005 and the bed will turn off.

Any delay that the front desk timer uses cannot be eclipsed by the T-Max® 005. The customer must wait the full delay time, in which case the bed will automatically come on.

If the session time on the T-Max® 005 eclipse's, but there is still contact closure on the input, a single period will be displayed on the T-Max® 005. Once the contact is removed from the TPI input, the next session can be started.

### 6.6 External speaker

An external speaker can be connected to the T-Max® 005 for make the beep louder. A T-Max® Speaker must be used. Connect the speaker to the connected shown in Figure A, Section 7.1, Set parameter 15 on the T-Max® 005 to a 1 as described in Section 2.2.

7 FIGURES

7.1 Figure A – Rear view of the T-Max® 005.

External Start.  
Connect a momentary push button to this terminal.  
This allows the user to press a button other than the Start/Stop button on the T-Max® 005 to start a session.

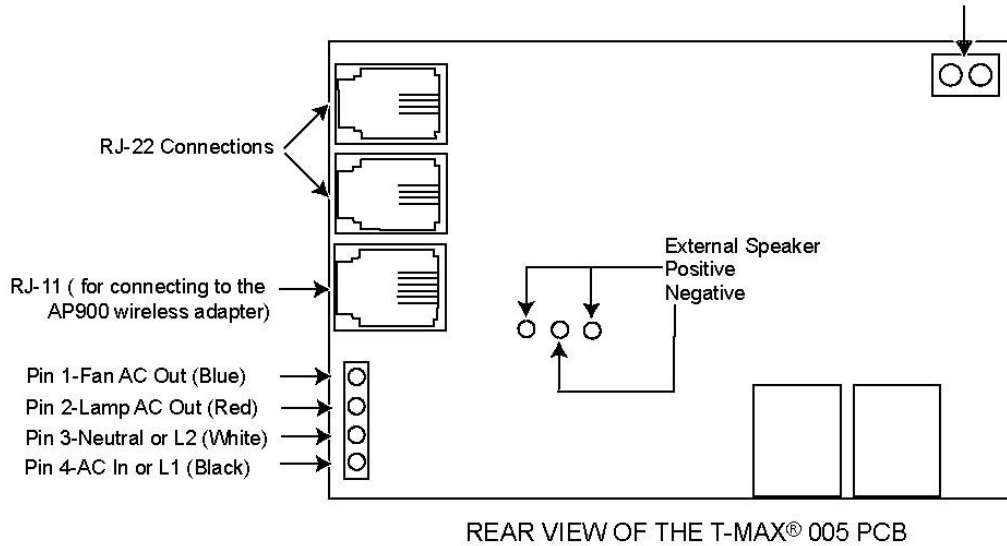

7.2 Figure B – Connecting the T-Max® 3A to a tanning bed with the 7.1 Figure A – Rear view of the T-Max® 005.

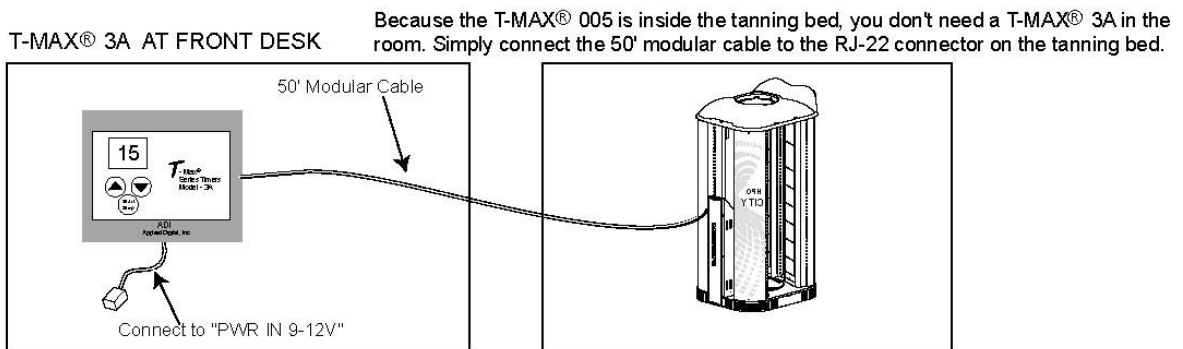

7.3 Figure C – TPI (Third Party Interface).

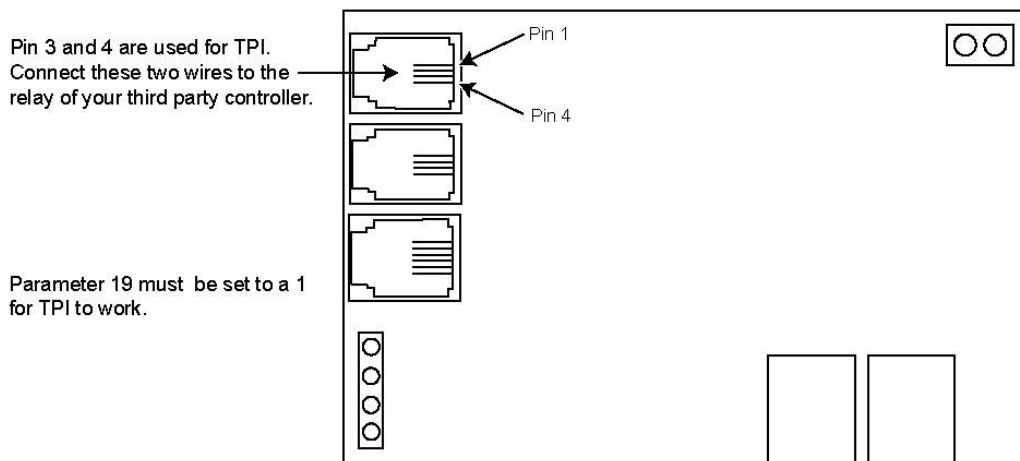

## 9 - TROUBLESHOOTING AND RAPID DIAGNOSTICS

### 9.1 TROUBLESHOOTING AND RAPID DIAGNOSTICS

- **The solarium does not switch on when START is pressed.**
  - 1 - Check the position of the lever on the breaker.
  - 2 - Check that the power supply terminal board MAL is in correct connection to the power supply.  
See "HPO EXOTIC\_\_2/11" circuit diagram.
  - 3 - Check the voltage (220V ~) across terminals BLACK and WHITE on board "T-MAX".  
See "HPO EXOTIC\_\_3/11" circuit diagram.
  - 4 - The lamps switch off and the control board is on. Otherwise, with the equipment in stand-by, the lamps do not come on when pressing start and the thermal protection comes into operation. Check that all the fans and hot air extractor fan work properly. (See chapter 7 "Extraordinary maintenance made by a skilled technician").
  
- **When START is pressed the ventilation system only is switched on.**
  - 1 - Check that remote control switches "HRV" operate correctly.  
See "HPO EXOTIC\_\_2/11-3/11" circuit diagram.
  - 2 - Check the voltage (220V ~) across terminals WHITE and BLUE on board "T-MAX".  
See "HPO EXOTIC\_\_3/11" circuit diagram.
  
- **When START is pressed only the lamps switch on (no ventilation).**
  - 1 - Check the voltage (220V ~) across terminals WHITE and RED on board "T-MAX".  
See "HPO EXOTIC\_\_3/11" circuit diagram.
  
- **Body cooling system inoperative or cannot be regulated.**
  - 1 - Check the fuse 2A on board "DMD-1".  
See "HPO EXOTIC\_\_3/11" circuit diagram.
  - 2 - Check the voltage ( variable up to a maximum of 230V ) across L1 and N of the connector "CNW2".  
See "HPO EXOTIC\_\_11/11" circuit diagram.
  
- **One of the high-pressure does not switch on.**
  - 1 - Check for voltage on the wiring to the lamp.
  - 2 - Check the ballast or the ignition for the lamp.
  - 3 - Check the fuses (F1÷F15) on the control board column.  
See "HPO EXOTIC\_\_2/11" circuit diagram.
  
- **The radio does not work.**
  - 1 - Check the fuses on the electronic board "AL12"
  - 2 - Check that the output of the power supply module "AL12" carries 12V DC.
  - 3 - The plugging in of jack plug of the earphones, excludes the loudspeaker functioning.  
See "HPO EXOTIC\_\_4/11" circuit diagram.

## 10 - DEMOLITION AND WASTE MATERIALS

### 10.1 WASTE MATERIALS

The lamps are considered as disposable waste materials and all the materials regarding the packing. Due to their characteristics, these lamps are classified as non-toxic and non-harmful **special waste materials**. Disposal of the lamps must therefore be effected as required by the appropriate legislation.

**DEFINITION OF SPECIAL WASTE MATERIAL:** Residual material deriving from industrial processes or agricultural, artisan, commercial or service activities which, in view of their quantity of characteristics, are not classified as normal household refuse.

### 10.2 DEMOLITION OF THE MACHINE

Each country applies specific legislation concerning the disposal of machinery. Disposal of this machine must be carried out in compliance with the regulations laid down by local legislation and bylaws. Dismantle the machine and group the various parts according to their chemical characteristics.

**Dismantling of the machine must be performed by qualified personnel**

**11 - CIRCUIT DIAGRAMS****11.1 CIRCUIT DIAGRAMS LEGEND**

SIMBOLS	DESCRIPTION		DESCRIPTION
	Ground terminal	RSP-LSP 4027.3030.04	Loudspeakers left
A1-A5 16973.000.1.0	Ballast for KALFASUN 1530F lamps	SA 4028.2185.09	Selector
AC1÷AC7 4028.4400.04	Igniter for KALFASUN 630F facial lamps	DMD-1 15906.067.0.0	Control board body fan
AC1-AC5 4028.4400.03	Igniter for KALFASUN 1530F facial lamps	SW 4026.1010.04 Scheda jack 15906.026.0.0	Limit switch  Circuit board for Jack
A1÷A7 16973.000.0.0	Ballast for KALFASUN 630F lamps	T 4028.2116.07	Timer TMP second lighting of lamps
AL12 4028.4400.03	Power supply circuit board for 12Vdc radio	T1 4028.2116.08	Safety timer
C1÷C4 C6÷C10 4028.4300.00	65µF condenser	TE 4028.2140.02	Thermic protection 120°
C2÷C5 C11÷C14 4028.4304.00	20µF condenser	CONNECTOR T-MAX 4026.0021.00	Control board T-MAX®
CNC	16-poles connector	VC 4028.0031.00	Body fan
CNR1-2-3	16-poles connector	VR 4028.0021.00	Cooling fan for ballasts cassette
CNRV CNGV CNG1-2-3	16-poles connector	VL1÷VL3 4028.0021.00	Cooling fans for face column lamps
CNW1-3	3-poles black connector	VL1÷VL3 4028.0029.04	Cooling fans for column lamps
CNW2	5-poles black connector	VP 4028.0050.00	Cooling fans for column lamps
CN4M CN4F	4-poles white connector	VE1-VE2 4028.049.00	Air exhaust fan
CN8M CN8F	8-poles white connector		
CO 4028.6000.01	Hour counter		
F17 4028.3126.14	Fuse 2A control board column (radio)		
F18 4028.3126.16	Fuse 6.3A control board column (12V illumination lamps)		
F19 4028.3126.15	Fuse 3.15A radio column (12V radio)		
F1÷F16 4028.3127.07	Fuse 15A M control board column (UV lamps)		
HR2-HRA 4028.2100.27	Contactora BF2600 for high pressure lamps		
HR1 4028.2100.28	Contactora BF50 for high pressure lamps		
HRV 4028.2100.24	Contactora BF1810 for ventilation lamps		
L1-L5 4028.4002.01	KALFASUN 1530F lamps		
L1÷L7 4028.4002.00	KALFASUN 630F lamps		
M1	19 poles terminal board		
M	Terminal board		
MAL	Power supply terminal board		
L1-L2-L3	Power supply phases		
RA 4027.3025.11	Radio/CD/MP3		

**DESCRIPTION CIRCUIT DIAGRAMS**

- 1/11 Voltage-change diagram.  
2/11 Practical diagram of column control board (power).  
3/11 Practical diagram of column control board (control).  
4/11 Practical diagram of radio column.  
5/11 Practical diagram of face ballasts box nr.1.  
6/11 Diagram ballasts box nr.2.  
7/11 Diagram ballasts box nr.3.  
8/11 Diagram ballasts box nr.4.  
9/11 Diagram of face column.  
10/11 Diagram of columns.  
11/11 Diagram fan cap.



**12 - WARRANTY**

**12.1 LIMITED WARRANTY**

For **USA** see next page.

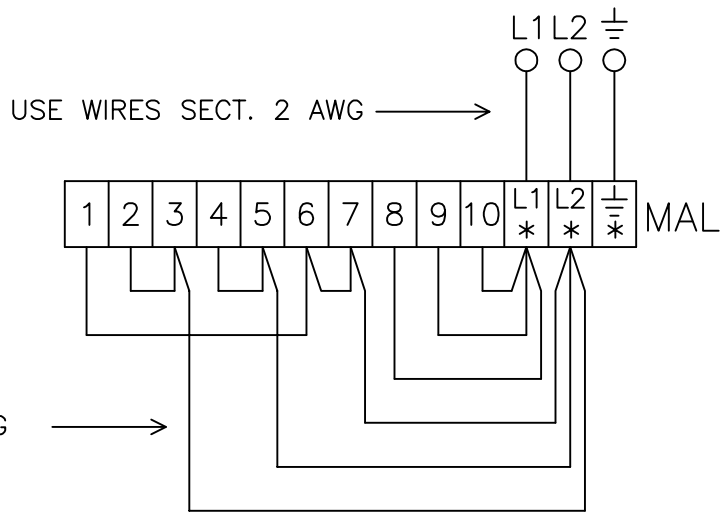

V = 230V MONO 60Hz

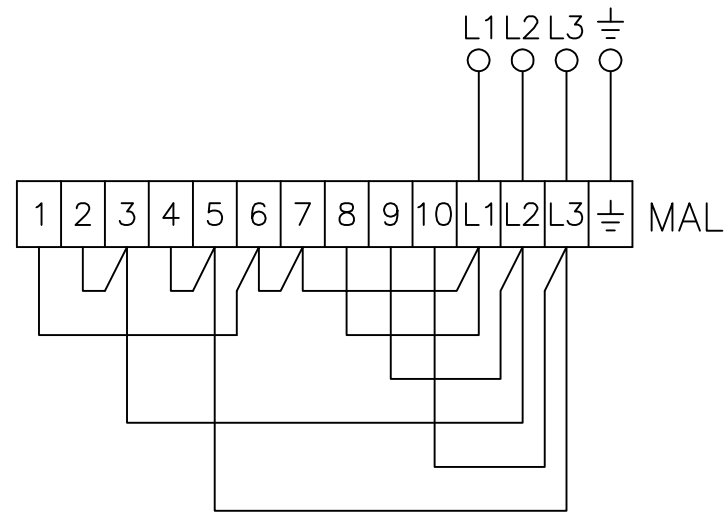

V = 230V 3F~ 60Hz

\* REPLACE TERMINALS INDICATED WITH 125Amps TERMINALS

SPORTARREDO SpA Via dell'Industria, 7 30020 GRUARO (VE) tel. 0421/767630 - fax 767635 PROPRIETÀ RISERVATA DELLA DITTA SPORTARREDO È vietato riprodurre o comunicare a terzi il contenuto del presente disegno	DESCRIZIONE: VOLTAGE-CHANGE DIAGRAM DIAGRAMM FÜR SPANNUNGSÄNDERUNG SCHEMA CAMBIO TENSIONE SCHEMA CHANGE TENSION ESQUEMA CAMBIO TENSION				Modello: HPD EXOTIC Versioni: USA T-MAX	
	CODICE: 10097.028.1.0 (220V 3F 60Hz)					
	Rif	Modifiche			Data	Firma
	a	-			-	-
	b	-			-	-
c	-			-	-	
d	-			-	-	
e	-			-	-	
CODICE CASS.\CABL: -					Schema: n° 1/12 Data: 30/06/2011 Dis: P.Pavan Contr: - file: 037_lusa.dwg	



DIAGRAM LEGEND	
HRV	Nr.1 CONTACTOR FOR VENTILATION LAMPS (HR1710)
HR1	Nr.1 CONTACTOR FOR 1st STARTING (HR46)
HR2	Nr.1 CONTACTOR FOR 2nd STARTING (HR2510)
C1-C2-C3-C4-C6-C8-C10-C11-C12	Nr.9 - 65 μF CONDENSER
C5-C7-C9-C13-C14	Nr.5 - 20 μF CONDENSER
F1-F17	Nr.17 - 15A AM FUSES
F18	Nr.1 - 6,3A T FUSES
T	Nr.1 TIMER
HRA	Nr.1 CONTACTOR FOR FACE LAMPS (HR1710)

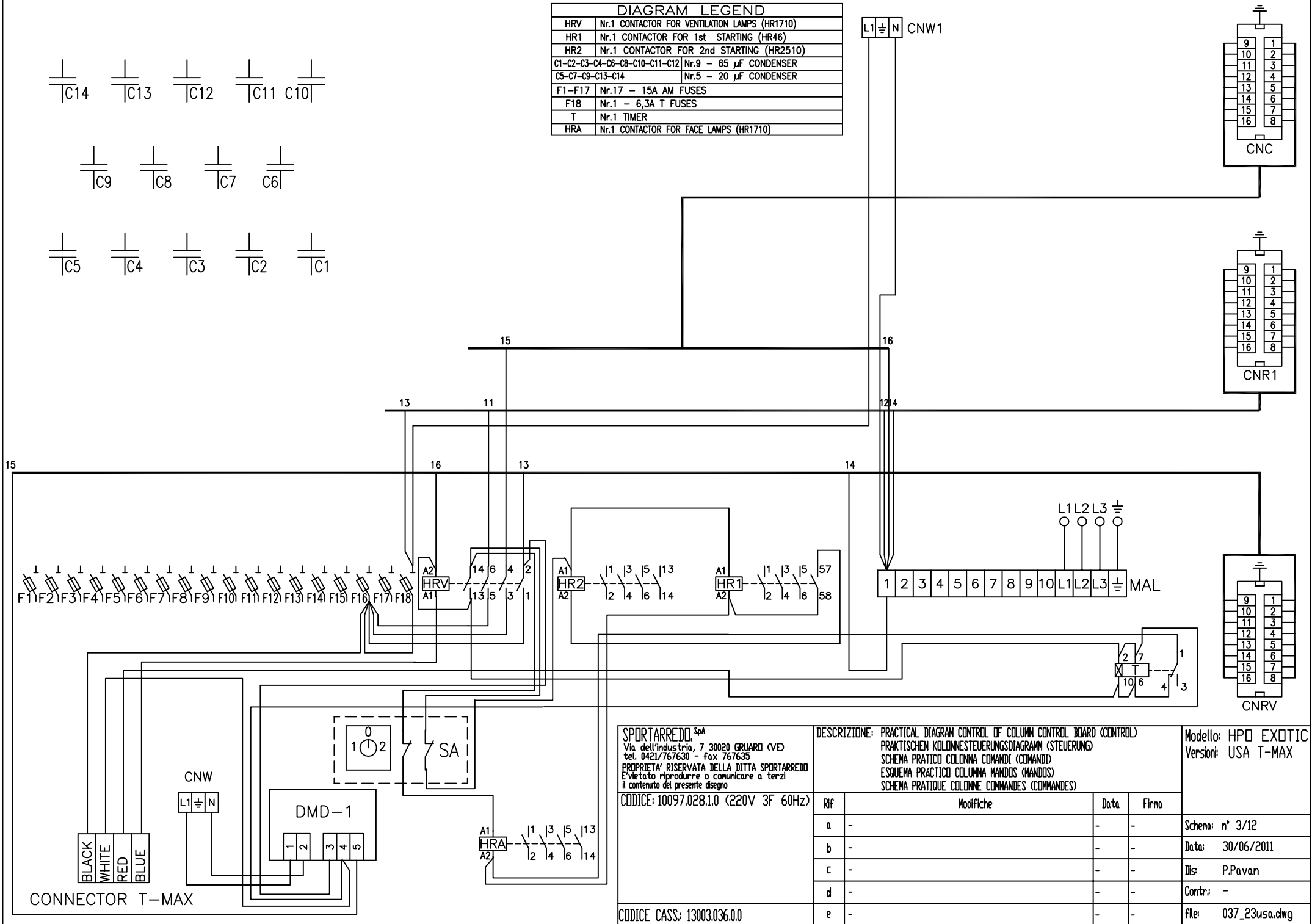
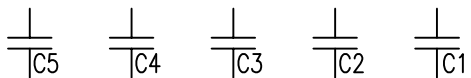
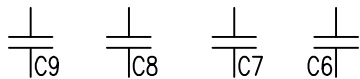
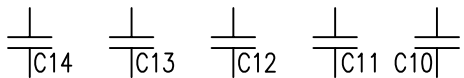

SPORTARREDO SpA  
 Via dell'Industria, 7 30020 GIUARD (VE)  
 tel. 0421/767630 - fax 767635  
 PROPRIETÀ RISERVATA DELLA DITTA SPORTARREDO  
 È vietato riprodurre o comunicare a terzi  
 il contenuto del presente disegno

CODICE: 10097.028.1.0 (220V 3F 60Hz)

DESCRIZIONE: PRACTICAL DIAGRAM CONTROL OF COLUMN CONTROL BOARD (CONTROL)  
 PRAKTISCHEN KOLONNENSTEUERUNGSDIAGRAMM (STEUERUNG)  
 SCHEMA PRATICO COLONNA COMANDI (COMANDI)  
 ESQUEMA PRÁCTICO COLUMNA MANDOS (MANDOS)  
 SCHEMA PRATIQUE COLONNE COMMANDES (COMMANDES)

Modello: HPD EXOTIC  
 Versioni: USA T-MAX

Rif	Modifiche	Data	Firma
a	-	-	-
b	-	-	-
c	-	-	-
d	-	-	-
e	-	-	-

Schema: n° 3/12
Data: 30/06/2011
Dls: P.Pavan
Contr: -
file: 037_23usa.dwg

CODICE CASS.: 13003.036.0.0

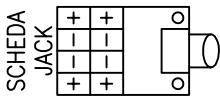
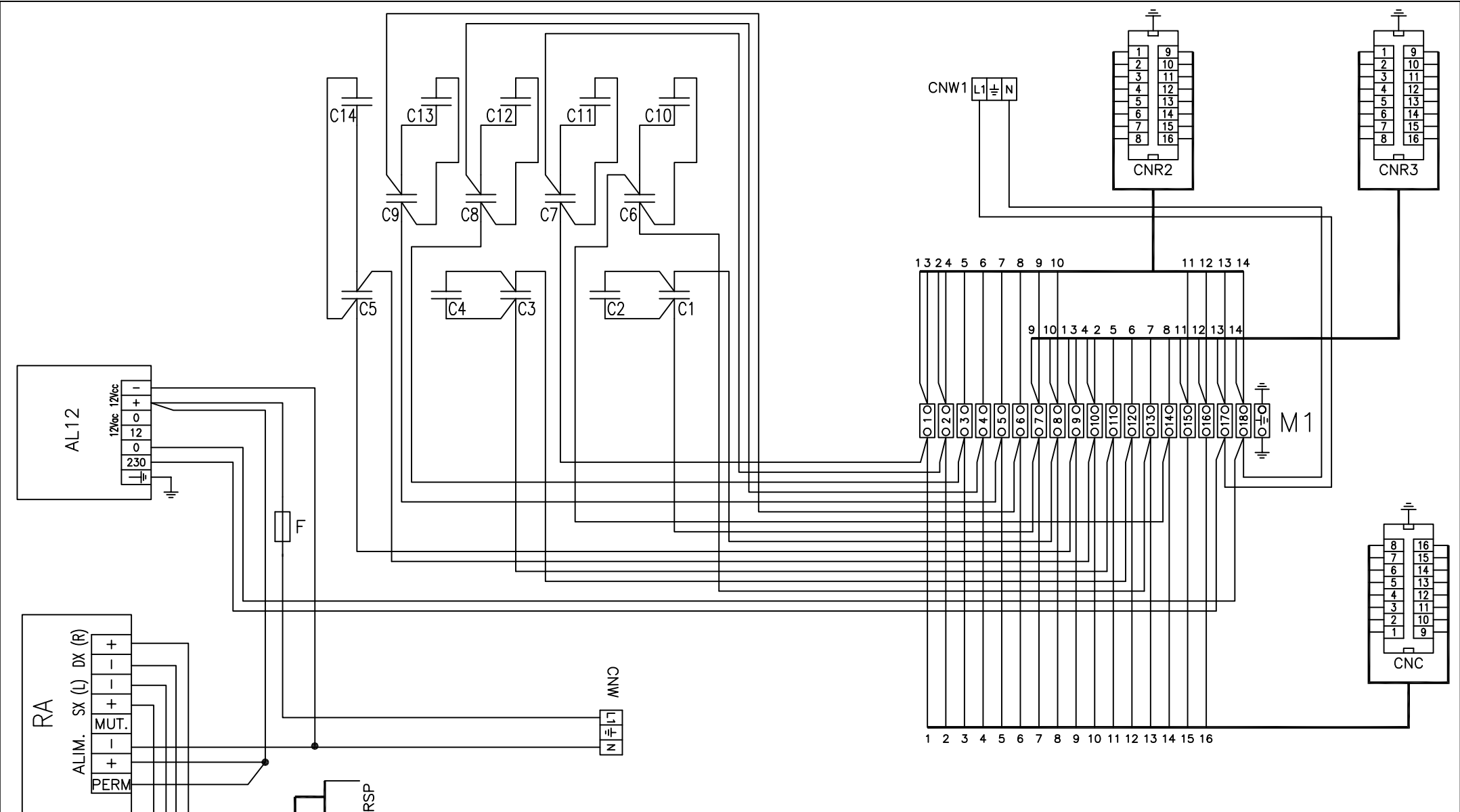

DIAGRAM LEGEND	
C1-C3-C5-C6-C7-C8-C9	Nr.7 - 65 µF CONDENSER
C2-C4-C10-C11-C12-C13-C14	Nr.7 - 20 µF CONDENSER
F	Nr.1 - 2,5A T FUSE

SPORTARREDDI SpA  
 Via dell'Industria, 7 30020 GRUARO (VE)  
 tel. 0421/767630 - fax 767635  
 PROPRIETÀ RISERVATA DELLA DITTA SPORTARREDDI  
 È vietato riprodurre o comunicare a terzi  
 il contenuto del presente disegno

CODICE: 10097.028.1.0 (220V 3F 60Hz)

DESCRIZIONE: PRACTICAL DIAGRAM OF RADIO COLUMN  
 SCHEMA PRATICO COLONNA AUTORADIO  
 PRAKTISCHEN KOLONNEAUTORADIODIAGRAMM  
 ESQUEMA PRACTICO COLUMNA RADIO  
 SCHEMA PRATIQUE COLONNE AUTO-RADIO

Modello: HPD EXOTIC  
 Versioni: USA T-MAX

Rif	Modifiche	Data	Firma
a	-	-	-
b	-	-	-
c	-	-	-
d	-	-	-
e	-	-	-

Schema: n° 4/12
Data: 30/06/2011
Dls: P.Pavan
Contr.: -
file: 037_4usa.dwg

CODICE CASS: 13003.064.0.0



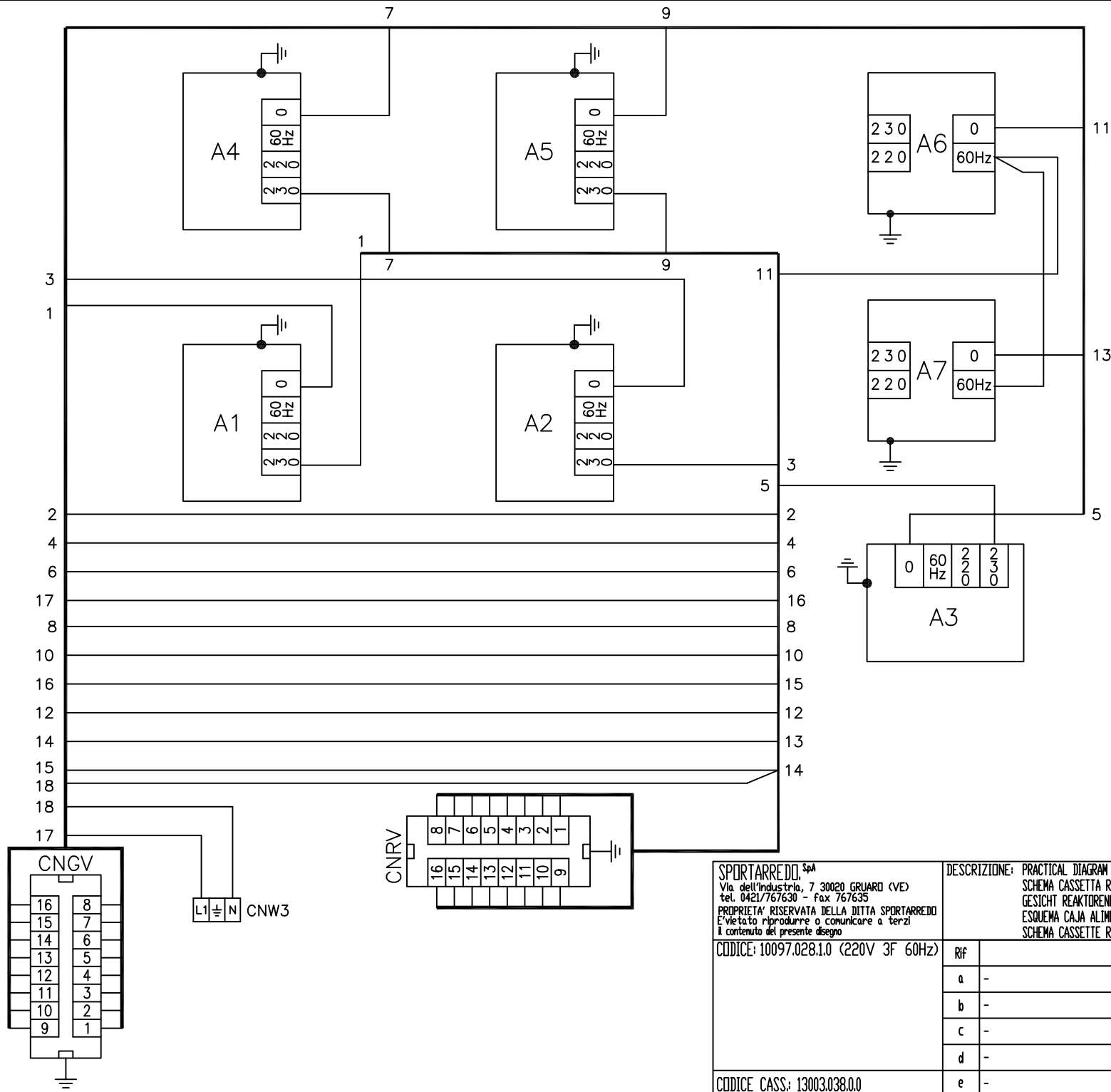

DIAGRAM LEGEND	
A1-A5	Nr.5 - 1400W BALLASTS HIGH PRESSURE
A6-A7	Nr.2 - 600W BALLASTS HIGH PRESSURE

SPORTARREDO SpA  
 Via dell'Industria, 7 30020 GRUARO (VE)  
 tel. 0421/767630 - fax 767635  
 PROPRIETÀ RISERVATA DELLA DITTA SPORTARREDO  
 È vietato riprodurre o comunicare a terzi  
 il contenuto del presente disegno

CODICE: 10097.028.1.0 (220V 3F 60Hz)

DESCRIZIONE: PRACTICAL DIAGRAM OF FACE FEEDERS BOX N°1  
 SCHEMA CASSETTA REATTORI N°1 VISO  
 GESICHT REAKTORENKASSETTEDIAGRAMM N°1  
 ESQUEMA CAJA ALIMENTADORES DE LA CARA N°1  
 SCHEMA CASSETTE REACTEURS VISAGE N°1

Modello: HPD EXOTIC  
 Versioni: USA T-MAX

Rif	Modifiche	Data	Firma
a	-	-	-
b	-	-	-
c	-	-	-
d	-	-	-
e	-	-	-

Schema: n° 5/12
Data: 30/06/2011
Dls: P.Pavan
Contr.: -
file: 037_5usa.dwg

CODICE CASS: 13003.038.0.0

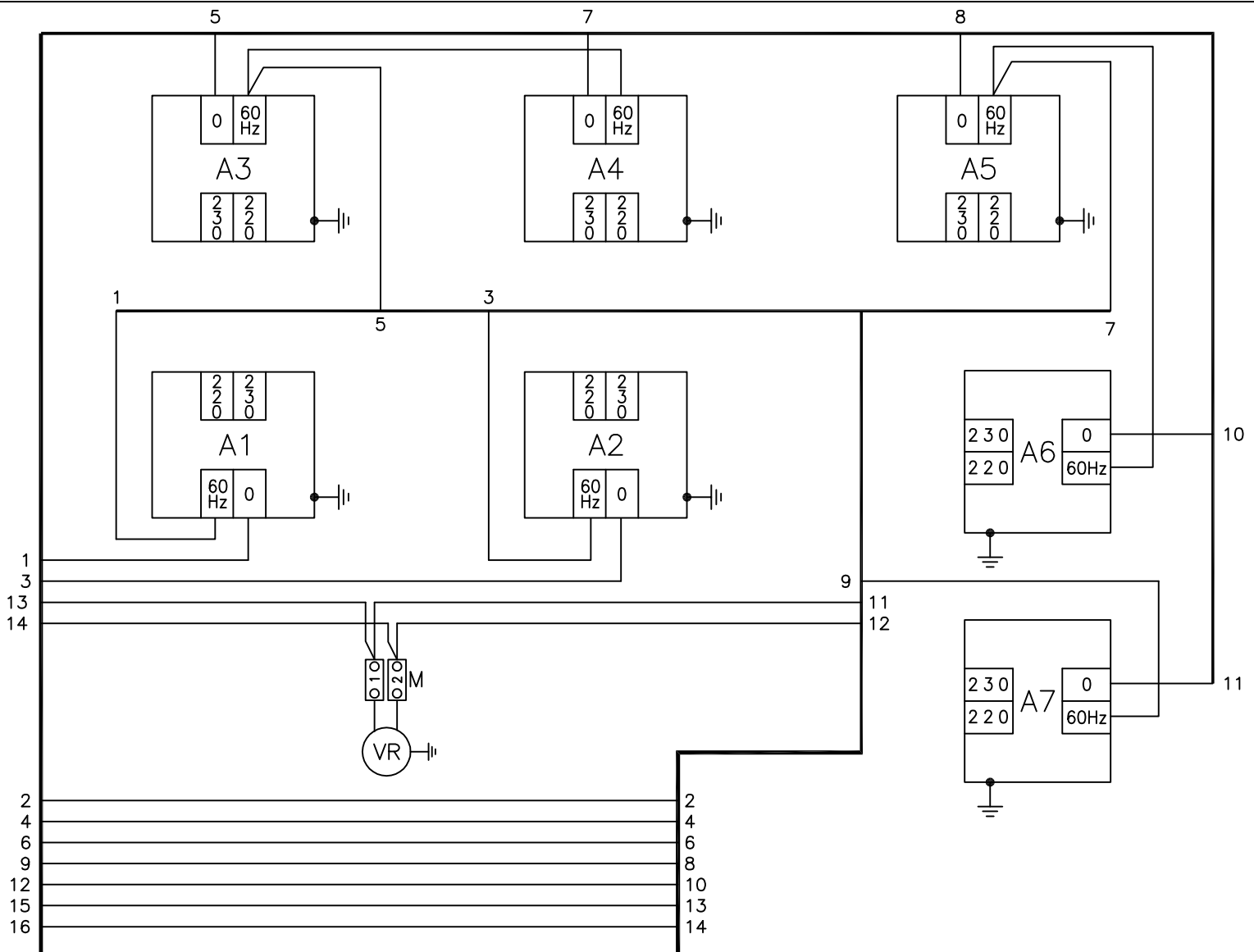
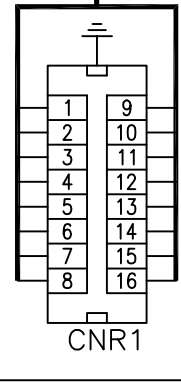
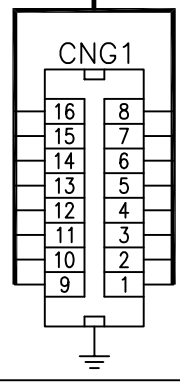

DIAGRAM LEGEND	
A1-A7	Nr.7 - 600W BALLASTS HIGH PRESSURE



SPORTARREDO SpA  
 Via dell'Industria, 7 30020 GRUARO (VE)  
 tel. 0421/767630 - fax 767635  
 PROPRIETÀ RISERVATA DELLA DITTA SPORTARREDO  
 È vietato riprodurre o comunicare a terzi  
 il contenuto del presente disegno  
 CODICE: 10097.028.1.0 (220V 3F 60Hz)

DESCRIZIONE: DIAGRAM BALLASTS BOX Nr.2 SCHEMA CASSETTA REATTORI N°2 REAKTORENKASSETTEDIAGRAMM NR.2 ESQUEMA CAJA ALIMENTADORES NR.2 SCHEMA CASSETTE REACTEURS NR.2		Modello: HPD EXOTIC Versioni: USA T-MAX	
Rif	Modifiche	Data	Firma
a	-	-	-
b	-	-	-
c	-	-	-
d	-	-	-
e	-	-	-

Schema: n° 6/12  
 Data: 30/06/2011  
 Dis: P.Pavan  
 Contr.: -  
 file: 037\_6usa.dwg

CODICE CASS: 13003.039.0.0

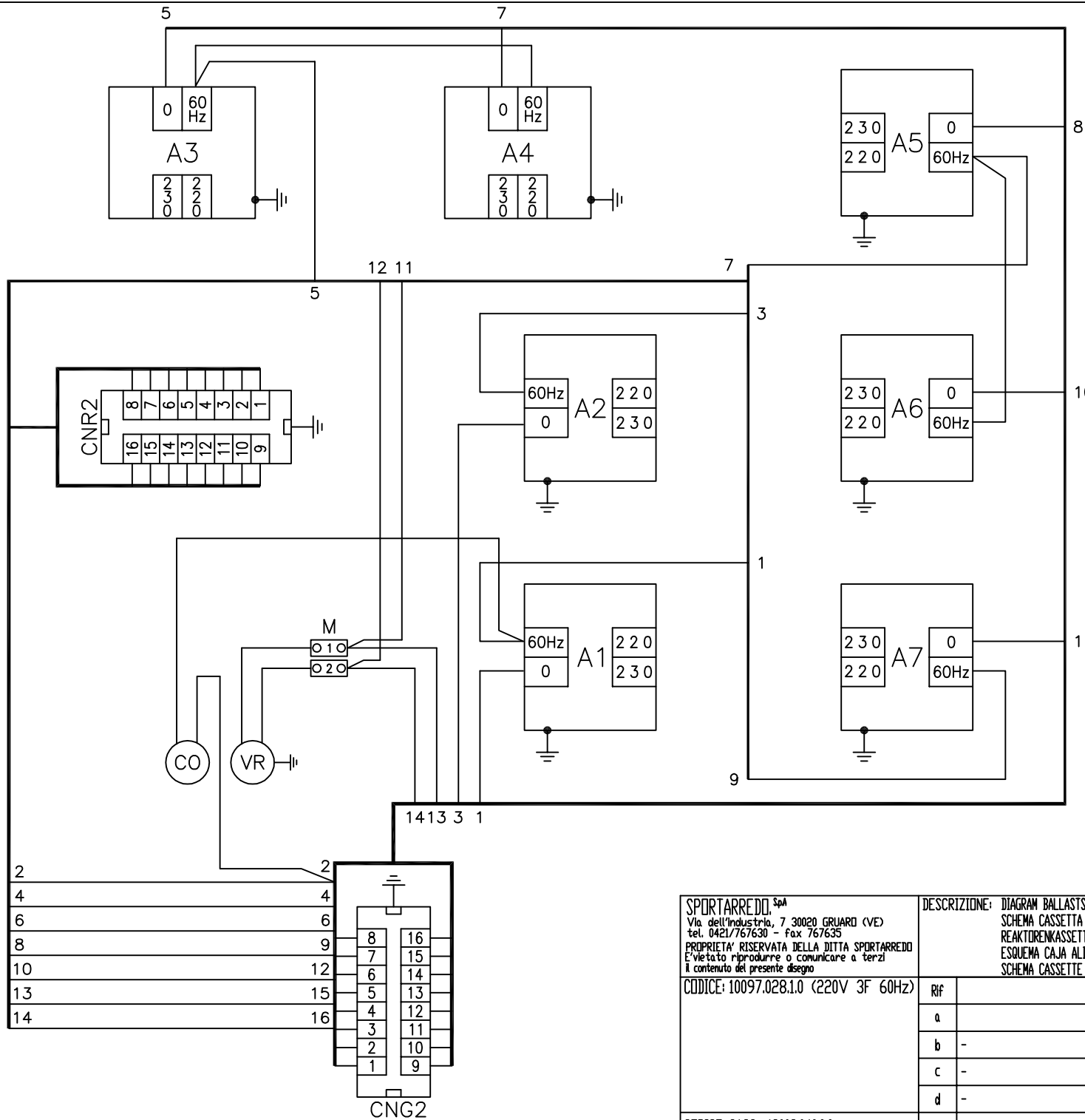

DIAGRAM LEGEND	
A1-A7	N.7 - 600W BALLASTS HIGH PRESSURE

SPORTARREDO, SpA  
 Via dell'Industria, 7 30020 GRUARO (VE)  
 tel. 0421/767630 - fax 767635  
 PROPRIETÀ RISERVATA DELLA DITTA SPORTARREDO  
 È vietato riprodurre o comunicare a terzi  
 il contenuto del presente disegno

CODICE: 10097.028.1.0 (220V 3F 60Hz)

DESCRIZIONE: DIAGRAM BALLASTS BDx Nr:3  
 SCHEMA CASSETTA REATTORI N°3  
 REAKTORENKASSETTEDIAGRAMM NR:3  
 ESQUEMA CAJA ALIMENTADORES NO:3  
 SCHEMA CASSETTE REACTEURS NR:3

Modello: HPD EXOTIC  
 Versioni: USA T-MAX

Rif	Modifiche	Data	Firma
a			
b	-	-	-
c	-	-	-
d	-	-	-
e	-	-	-

Schema: n° 7/12
Data: 30/06/2011
Dls: P.Pavan
Contr.: -
file: 037_7usa.dwg

CODICE CASS: 13003.040.0.0

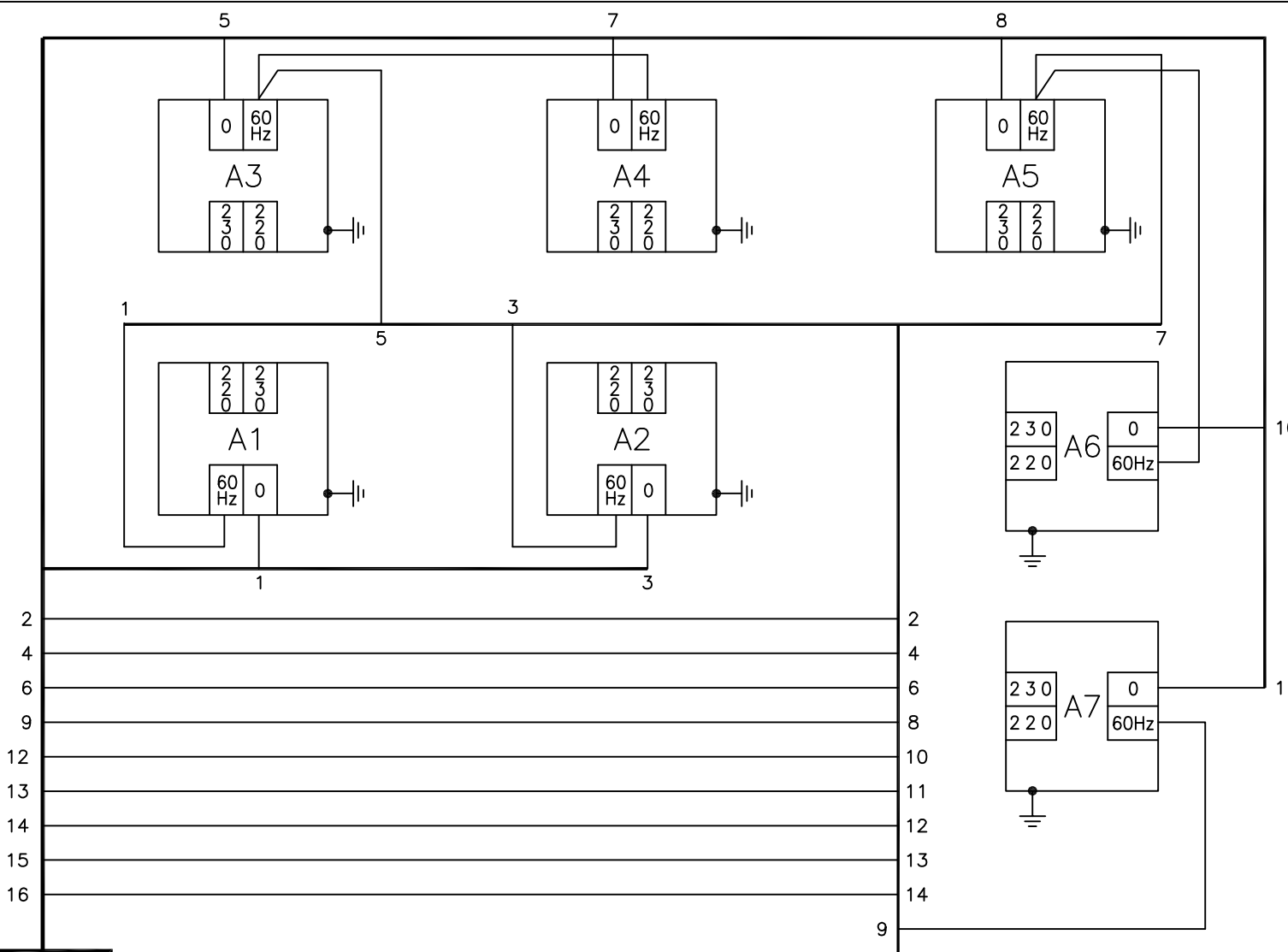

**DIAGRAM LEGEND**

A1-A7	Nr.7 - 600W BALLAST HIGH PRESSURE
-------	-----------------------------------

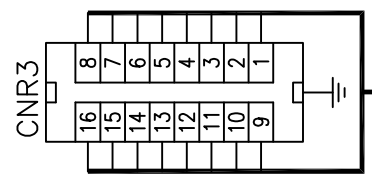
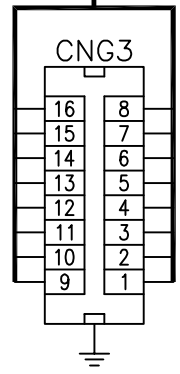

**SPORTARREDO SpA**  
 Via dell'Industria, 7 30020 GRUARO (VE)  
 tel. 0421/767630 - fax 767635  
 PROPRIETÀ RISERVATA DELLA DITTA SPORTARREDO  
 È vietato riprodurre o comunicare a terzi  
 il contenuto del presente disegno

CODICE: 10097.028.1.0 (220V 3F 60Hz)

**DESCRIZIONE:** DIAGRAM BALLASTS BDx Nr.4  
 SCHEMA CASSETTA REATTORI N°4  
 REAKTORENKASSETTEDIAGRAMM NR.4  
 ESQUEMA CAJA ALIMENTADORES N.4  
 SCHEMA CASSETTE REACTEURS NR.4

Modello: HPD EXOTIC  
 Versioni: USA T-MAX

Rif	Modifiche	Data	Firma
a	-	-	-
b	-	-	-
c	-	-	-
d	-	-	-
e	-	-	-

CODICE CASS: 13003.041.0.0

Schema: n° 8/12  
 Data: 30/06/2011  
 Dis: P.Pavan  
 Contr: -  
 file: 037\_8usa.dwg

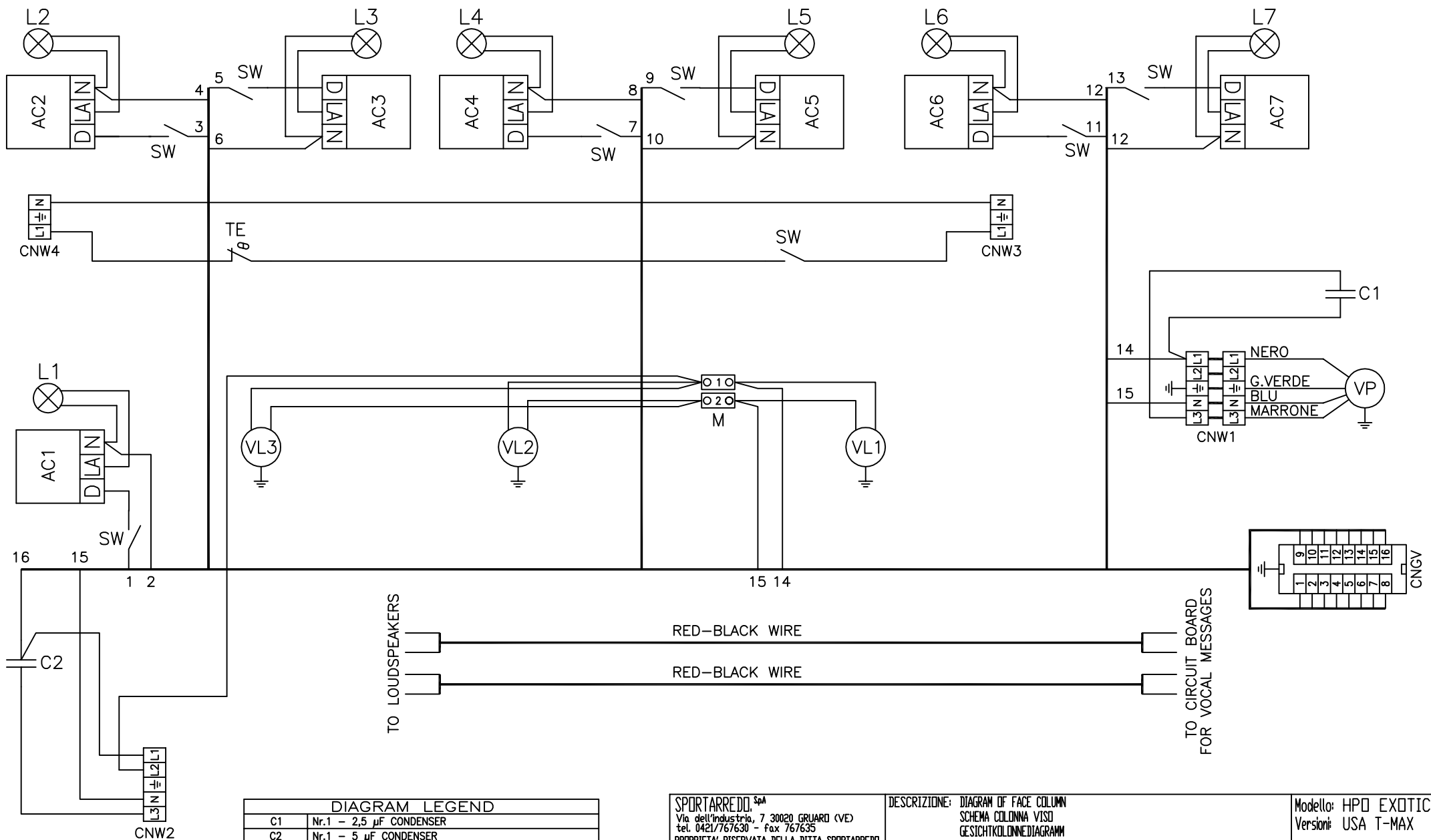

DIAGRAM LEGEND	
C1	Nr.1 - 2,5 µF CONDENSER
C2	Nr.1 - 5 µF CONDENSER
AC1-AC5	Nr.5 - 1000W IGNITERS
AC6-AC7	Nr.2 - 600W IGNITERS
L1-L5	Nr.5 -1500W HIGH PRESSURE LAMPS
L6-L7	Nr.2 - 600W HIGH PRESSURE LAMPS
TE	Nr.1 - HEAT SENSOR 120°
SW	Nr.8 - MICROSWITCH

SPORTARREDO SpA  
 Via dell'Industria, 7 30020 GRUARO (VE)  
 tel. 0421/767630 - fax 767635  
 PROPRIETÀ RISERVATA DELLA DITTA SPORTARREDO  
 È vietato riprodurre o comunicare a terzi  
 il contenuto del presente disegno  
 CODICE: 10097.028.1.0 (220V 3F 60Hz)  
 CODICE CABL.: 17073.155.0.0

DESCRIZIONE: DIAGRAM OF FACE COLUMN SCHEMA COLONNA VISIO GESICHTSKOLONNEDIAGRAMM ESQUEMA PRACTICO COLUMNA CARA SCHEMA COLONNE VISAGE			
Rif	Modifiche	Data	Firma
a	-	-	-
b	-	-	-
c	-	-	-
d	-	-	-
e	-	-	-

Modello: HPD EXOTIC  
 Versioni: USA T-MAX  
 Schema: n° 9/12  
 Data: 30/06/2011  
 Dis: P.Pavan  
 Contr: -  
 File: 037\_9usa.dwg



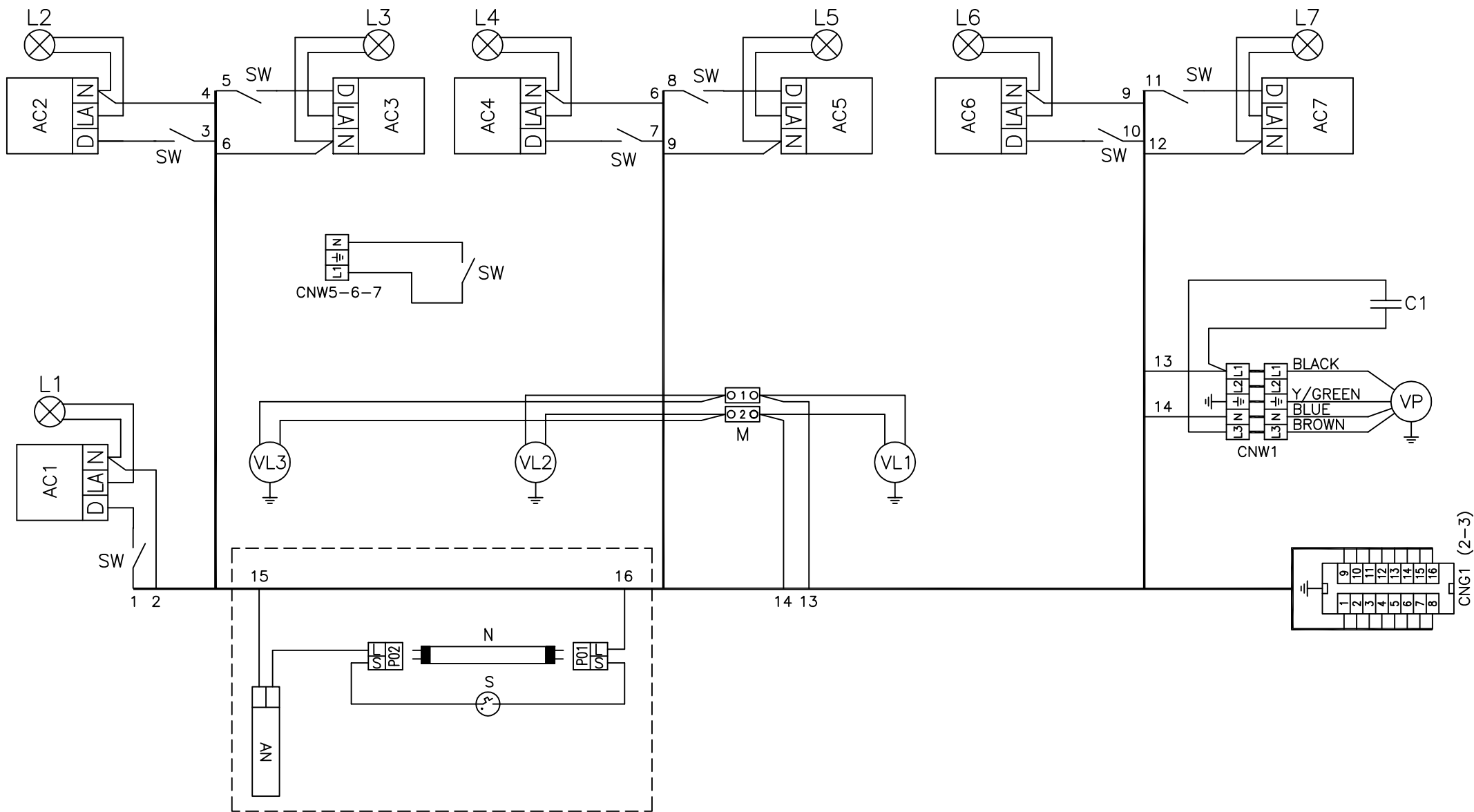

ON ILLUMINATION COLUMN ONLY

DIAGRAM LEGEND	
C1	Nr.1 - 2,5 µF CONDENSER
AC1-AC7	Nr.7 - 600W IGNITERS
L1-L7	Nr.7 - 600W HIGH PRESSURE LAMPS
N	Nr.1 - 56W LAMP
AN	Nr.1 - 56W BALLAST
SW	Nr.8 - MICROSWITCH

SPORTARREDO SpA  
 Via dell'Industria, 7 30020 GRUARDO (VE)  
 tel. 0421/767630 - fax 767635  
 PROPRIETÀ RISERVATA DELLA DITTA SPORTARREDO  
 È vietato riprodurre o comunicare a terzi  
 il contenuto del presente disegno

CODICE: 10097.028.1.0 (220V 3F 60Hz)

DESCRIZIONE: DIAGRAM OF COLUMN  
 SCHEMA COLONNA  
 KOLONNEDIAGRAMM  
 ESQUEMA COLUMNA  
 SCHEMA COLUMNNE

Modello: HPD EXOTIC  
 Versioni: USA T-MAX

Rif	Modifiche	Data	Firma
a	-	-	-
b	-	-	-
c	-	-	-
d	-	-	-
e	-	-	-

Schema: n° 10/12  
 Data: 30/06/2011  
 Dis: P.Pavan  
 Contr: -  
 File: 037\_10usa.dwg

CODICE CABL.: 17073.153.0.0/17073.154.0.0

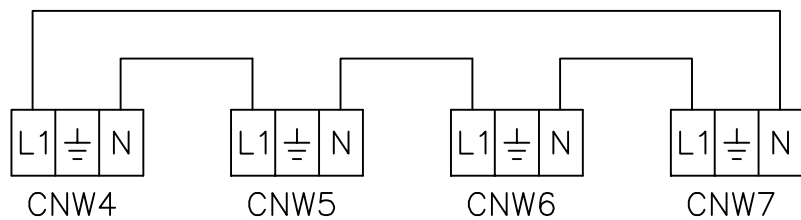
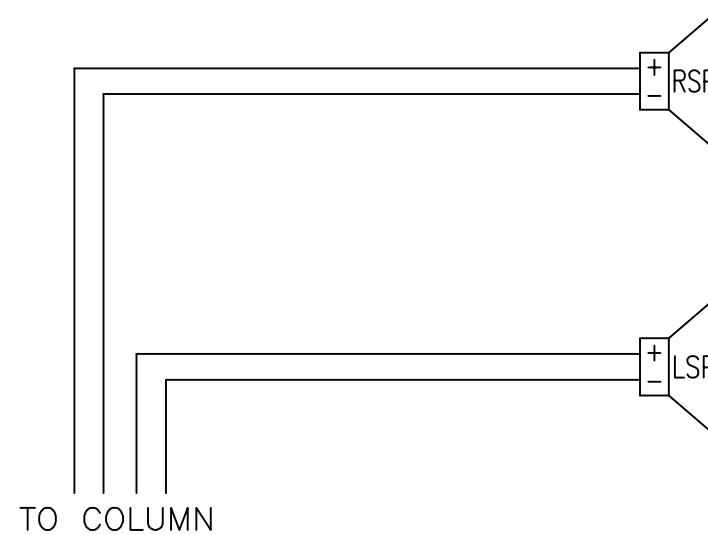
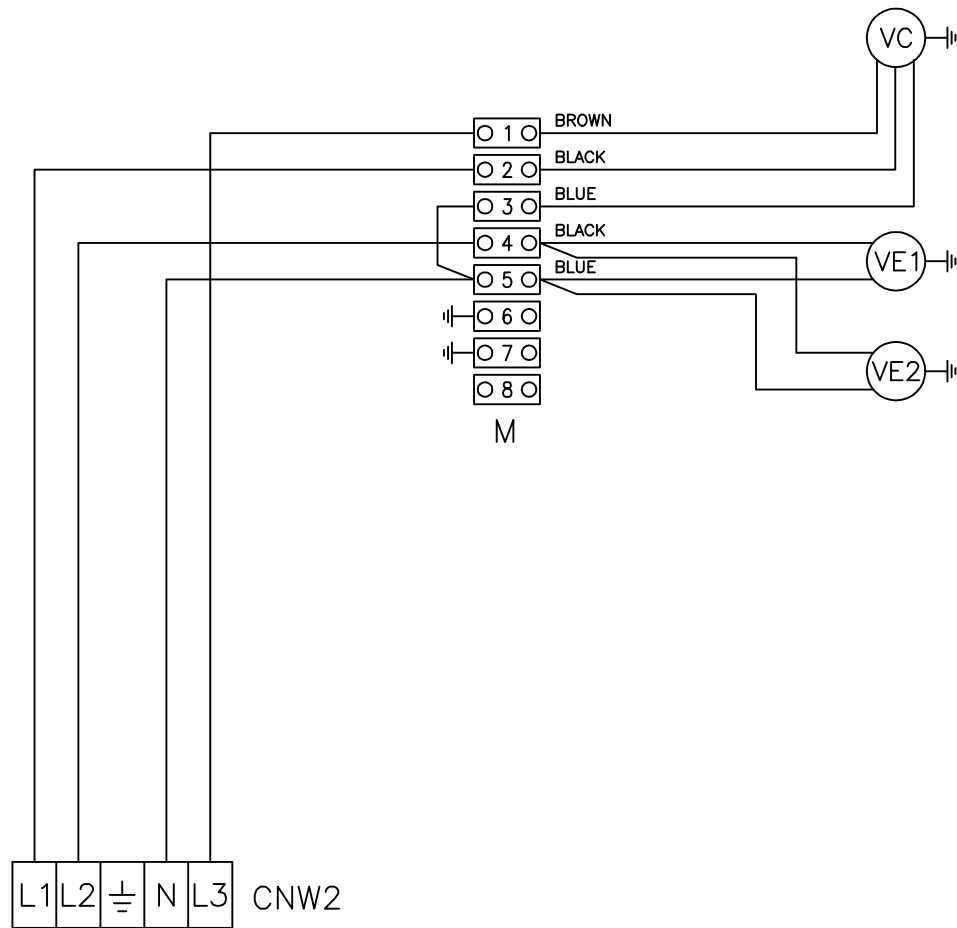

SPORRARREDO, SpA Via dell'Industria, 7 30020 GRUARO (VE) tel. 0421/767630 - fax 767635 PROPRIETÀ RISERVATA DELLA DITTA SPORRARREDO È vietato riprodurre o comunicare a terzi il contenuto del presente disegno CODICE: 10097.028.1.0 (220V 3F 60Hz)	DESCRIZIONE: DIAGRAM FAN CAP SCHEMA VENTILAZIONE CAPPELLO KAPUZELLEFTUNGSDIAGRAMM ESQUEMA VENTILACION DE LA TAPA SCHEMA VENTILATION CAPUCHON			Modello: HPD EXOTIC Versioni: USA T-MAX	
	Rif	Modifiche	Data	Firma	
	a	-	-	-	Schema: n° 11/12
	b	-	-	-	Data: 30/06/2011
	c	-	-	-	Dls: P.Pavan
d	-	-	-	Contr.: -	
CODICE CABL./CASS:	e	-	-	file: 037_11usa.dwg	

FUSE n°	A	PROTECTION
F	2,5 delay	VOCAL BOARD (NOT US VERSION)
1	15 delay	LAMP N°1 1500W FACE COLUMN n°1
2	15 delay	LAMP N°2 1500W FACE COLUMN n°1
3	15 delay	LAMP N°3 1500W FACE COLUMN n°1 AND LAMP N°1 600W COLUMN n°2
4	15 delay	LAMP N°4 1500W FACE COLUMN n°1 AND LAMP N°2 600W COLUMN n°2
5	15 delay	LAMP N°5 1500W FACE COLUMN n°1 AND LAMP N°7 600W COLUMN n°2
6	15 delay	LAMP N°6-7 600W FACE COLUMN n°1
7	15 delay	LAMP N°3-4 600W COLUMN n°2
8	15 delay	LAMP N°5-6 600W COLUMN n°2
9	15 delay	LAMP N°1-2 600W COLUMN n°3
10	15 delay	LAMP N°3-4 600W COLUMN n°3
11	15 delay	LAMP N°5-6 600W COLUMN n°3
12	15 delay	LAMP N°7 600W COLUMN n°3 LAMP N°7 600W COLUMN n°4
13	15 delay	LAMP N°1-2 600W COLUMN n°4
14	15 delay	LAMP N°3-4 600W COLUMN n°4
15	15 delay	LAMP N°5-6 600W COLUMN n°4
16	15 delay	VENTILATIONS AND COMMAND
17	6,3 delay	ILLUMINATION COLUMN AND 12Vac TRANSFORMER

CONNECTOR A	POSITION (A) ←	→ POSITION (B)	CONNECTOR B
CNRV	COMMAND COLUMN	BALLAST TRAY FACE COLUMN n°1	CNRV
CNR1	COMMAND COLUMN	BALLAST TRAY n°2	CNR1
CNC	COMMAND COLUMN	RADIO COLUMN	CNC
CNGV	BALLAST TRAY FACE COLUMN n°1	FACE COLUMN n°1	CNGV
CNR2	RADIO COLUMN	BALLAST TRAY n°3	CNR2
CNR3	RADIO COLUMN	BALLAST TRAY n°4	CNR3
CNG1	BALLAST TRAY n°2	COLUMN n°2	CNG1
CNG2	BALLAST TRAY n°3	COLUMN n°3	CNG2
CNG3	BALLAST TRAY n°4	COLUMN n°4	CNG3
CNW1	COMMAND COLUMN	RADIO COLUMN	CNW1
CNW	COMMAND COLUMN	COIN BOX	CNW
CN4M	COMMAND COLUMN	RADIO COLUMN	CN4F
CN8M	COMMAND COLUMN	RADIO COLUMN	CN8F
CNW3	BALLAST TRAY FACE COLUMN n°1	FACE COLUMN	CNW3
CNW4	FACE COLUMN	TOP	CNW4
CNW5	COLUMN n°1	TOP	CNW5
CNW6	COLUMN n°2	TOP	CNW6
CNW7	COLUMN n°3	TOP	CNW7
CNW2	FACE COLUMN	TOP	CNW2

<b>SPORTARREDDI, S.p.A.</b> Via dell'Industria, 7 30020 GRUARO (VE) tel. 0421/767630 - fax 767635 PROPRIETÀ RISERVATA DELLA DITTA SPORTARREDDO È vietato riprodurre o comunicare a terzi il contenuto del presente disegno.		<b>DESCRIZIONE:</b> SCHEMA FUSIBILI E CONNETTORI FUSES AND CONNECTOR DIAGRAM SCHMELZ UND VERBINDER DIAGRAM SCHEMA FUSIBLES ET CONNECTEUR ESQUEMA FUSIBLES Y CONECTORES		Modello: HPO EXOTIC Version# USA T-MAX	
CODICE: 10097028.10 (220V 3F 60Hz)		Rif	Modifiche	Data	Firma
		a	-	-	-
		b	-	-	-
		c	-	-	-
		d	-	-	-
		e	-	-	-
CODICE CABL./CASS.:					
		Schema n° 12/12		Data: 30/06/2011	
		Dis: P.Povan		Contr: -	
		file: 037_12uscadwg			